

ENGINEERING DRAWING

(NSQF)

(As per Revised Syllabus July 2022)

Group 14

Rubber Technician



Directorate General of Training

DIRECTORATE GENERAL OF TRAINING
MINISTRY OF SKILL DEVELOPMENT & ENTREPRENEURSHIP
GOVERNMENT OF INDIA



**NATIONAL INSTRUCTIONAL
MEDIA INSTITUTE, CHENNAI**

Post Box No. 3142, CTI Campus, Guindy, Chennai - 600 032

Engineering Drawing (NSQF) 1 Year
Group 14 Engineering Trades
As per Revised syllabus July 2022 under CTS

Developed & Published by



National Instructional Media Institute

Post Box No.3142
Guindy, Chennai - 600032
INDIA
Email: chennai-nimi@nic.in
Website: www.nimi.gov.in

Copyright © 2023 National Instructional Media Institute, Chennai

First Edition : December 2023

Copies : 1000

Rs. 95/-

All rights reserved.

No part of this publication can be reproduced or transmitted in any form or by any means, electronic or mechanical, including photocopy, recording or any information storage and retrieval system, without permission in writing from the National Instructional Media Institute, Chennai.

FOREWORD

The Government of India has set an ambitious target of imparting skills one out of every four Indians, to help them secure jobs as part of the National Skills Development Policy. Industrial Training Institutes (ITIs) play a vital role in this process especially in terms of providing skilled manpower. Keeping this in mind, and for providing the current industry relevant skill training to Trainees, ITI syllabus has been recently updated with the help of comprising various stakeholder's viz. Industries, Entrepreneurs, Academicians and representatives from ITIs.

The National Instructional Media Institute (NIMI), Chennai, has now come up with instructional material to suit the revised curriculum for **Engineering Drawing NSQF Group 14 Engineering Trades (Revised 2022)** under CTS will help the trainees to get an international equivalency standard where their skill proficiency and competency will be duly recognized across the globe and this will also increase the scope of recognition of prior learning. NSQF trainees will also get the opportunities to promote life long learning and skill development. I have no doubt that with NSQF the trainers and trainees of ITIs, and all stakeholders will derive maximum benefits from these IMPs and that NIMI's effort will go a long way in improving the quality of Vocational training in the country.

The Director General, Executive Director & Staff of NIMI and members of Media Development Committee deserve appreciation for their contribution in bringing out this publication.

Jai Hind

ATUL KUMAR TIWARI, I.A.S

Secretary

Ministry of Skill Development & Entrepreneurship,
Government of India.

December 2023

New Delhi - 110 001

PREFACE

The National Instructional Media Institute(NIMI) was set up at Chennai, by the Directorate General of Training, Ministry of skill Development and Entrepreneurship, Government of India, with the technical assistance from the Govt of the Federal Republic of Germany with the prime objective of developing and disseminating instructional Material for various trades as per prescribed syllabus and Craftsman Training Programme(CTS) under NSQF levels.

The Instructional materials are developed and produced in the form of Instructional Media Packages (IMPs), consisting of Trade Theory, Trade Practical, Test and Assignment Book, Instructor Guide, Wall charts. The above material will enable to achieve overall improvement in the standard of training in ITIs.

A national multi-skill programme called SKILL INDIA, was launched by the Government of India, through a Gazette Notification from the Ministry of Finance (Dept of Economic Affairs), Govt of India, dated 27th December 2013, with a view to create opportunities, space and scope for the development of talents of Indian Youth, and to develop those sectors under Skill Development.

The emphasis is to skill the Youth in such a manner to enable them to get employment and also improve Entrepreneurship by providing training, support and guidance for all occupation that were of traditional types. The training programme would be in the lines of International level, so that youths of our Country can get employed within the Country or Overseas employment. The **National Skill Qualification Framework (NSQF)**, anchored at the National Skill Development Agency(NSDA), is a Nationally Integrated Education and competency-based framework, to organize all qualifications according to a series of **levels of Knowledge, Skill and Aptitude**. Under NSQF the learner can acquire the Certification for Competency needed at any level through formal, non-formal or informal learning.

The **Engineering Drawing** NSQF Group 14 - Engineering Trades (Revised 2022) under CTS is one of the book developed by the core group members as per the NSQF syllabus.

The **Engineering Drawing** NSQF Group 14 - Engineering Trades under (Revised 2022) CTS as per NSQF is the outcome of the collective efforts of experts from Field Institutes of DGT, Champion ITI's for each of the Sectors, and also Media Development Committee (**MDC**) members and Staff of **NIMI**. NIMI wishes that the above material will fulfill to satisfy the long needs of the trainees and instructors and shall help the trainees for their Employability in Vocational Training.

NIMI would like to take this opportunity to convey sincere thanks to all the Members and Media Development Committee (MDC) members.

Chennai - 600 032

EXECUTIVE DIRECTOR

ACKNOWLEDGEMENT

The National Instructional Media Institute (NIMI) sincerely acknowledge with thanks the co-operation and contribution of the following Media Developers to bring this IMP for the course **Engineering Drawing Group 14 - Engineering Trades** as per NSQF Revised 2022.

MEDIA DEVELOPMENT COMMITTEE MEMBERS

Shri. M. Sangara pandian	-	Training Officer (Retd.) CTI, Govt. of India, Guindy, Chennai - 32.
Shri. G. Sathiamoorthy	-	Jr. Training Officer - SG (Retd.) Govt I.T.I, Trichy, DET - Tamilnadu.
Shri. R. Sekaran	-	Jr. Training Officer (Retd.), Govt I.T.I, Ambattur, Chennai - 600098.

NIMI CO-ORDINATORS

Shri. Nirmalya Nath	-	Deputy General Manager, NIMI, Chennai - 32.
Shri. G. Michael Johny	-	Manager, NIMI, Chennai - 32.

NIMI records its appreciation of the **Data Entry, CAD, DTP Operators** for their excellent and devoted services in the process of development of this IMP.

NIMI also acknowledges with thanks, the efforts rendered by all other staff who have contributed for the development of this book.

INTRODUCTION

Theory and procedure along with the related exercises for further practice

This book on theory and procedure along with related exercises contains theoretical information on **1 Year Engineering drawing** NSQF (Revised syllabus July 2022 Group 14 - Engineering Trades) and procedure of drawing/ sketching different exercise for further practice are also available. Wherever required, BIS specification has been used.

Exercise for further practice

The practice exercise is given with Theory and procedure for 1 Year book made obsolete as it was felt that, it is very difficult to work in workbook using drawing instruments. It is well known fact that, any drawing is prepared on suitable standard size of drawing sheets only.

The instructor is herewith advised to go through the instructions given below and to follow them in view of imparting much drawing skill in the trainees.

Acquiring the above said ability and doing small drawings is not a simple task. These books will provide a good platform for achieving the said skills.

Time allotment - 1 Year : 40 Hrs

Sl. No.	Topic	Exercise No.	Time Allotment
1	Introduction to Engineering Drawing and Drawing Instruments	1.1.01 - 1.1.05	2
2	Free hand drawing	1.2.06 - 1.2.08	6
3	Drawing of Geometrical Figures	1.3.09 - 1.3.12	10
4	Reading of dimension and Dimensioning Practice.	1.4.13 & 1.4.14	4
5	Symbolic Representation	1.5.15	8
6	Reading of Job drawing of related trades	1.6.16	10
			40 Hrs

Instructions to the Instructors

It is suggested to get the drawing prepared on A4/A3 sheets preferably on only one side. If separate table and chair facility is available for every trainee then it is preferred to use A3 sheets and if the drawing hall is provided with desks then A4 sheets may be used. However while preparing bigger drawings on A4 sheets suitable reduction scale to be used or multiple sheets may be used for detailed and assembly drawings.

First the border and the title block to be drawn only for the first sheet of the chapter. Eg. for conical sections only first sheet will have the title block whereas the rest of the sheets of that chapter will have only borders.

Serial number of sheet and total no. of sheets to be mentioned on each sheet.

The completed sheet to be punched and filled in a box file/ suitable files and preserved by the trainees carefully after the approval of instructor, VP and Principal of the Institute.

The file may be referred by the authority before granting the internal marks at the end of the Year.

CONTENTS

Exercise No.	Topic of the Exercise	Page No.
	Introduction to engineering drawing and drawing instruments	
1.1.01	Introduction to engineering drawing and drawing instruments	1
1.1.02	Conventions	4
1.1.03	Sizes and layout of drawing sheets	5
1.1.04	Title block, its position and content	7
1.1.05	Drawing instruments	11
	Free hand drawing	
1.2.06	Free hand drawing of - Geometrical figures and blocks with dimension	16
1.2.07	Free hand drawing of - Transferring measurement from the given object to the free hand sketches	19
1.2.08	Free hand drawing of hand tools and measuring tools	23
	Drawing of Geometrical Figures	
1.3.09	Drawing of geometrical figures - Angle & triangle	30
1.3.10	Drawing of geometrical figures - Circle	33
1.3.11	Drawing of geometrical figures - Square, rectangle and parallelogram	35
1.3.12	Lettering and numbering - Single stroke	37
	Reading of dimension and Dimensioning Practice	
1.4.13	Reading of dimension and dimensioning practice - Dimensioning	41
1.4.14	Practice of dimensioning	43
	Symbolic Representation	
1.5.15	Symbolic representation - Different symbols used in the rubber technician trade	46
	Reading of Job drawing of related trades	
1.6.16	Reading of job/ process drawing related to rubber technician trade	47

LEARNING / ASSESSABLE OUTCOME

On completion of this book you shall be able to

- **Read and apply engineering drawing for different application in the field of work.**

SYLLABUS

1 Year

Group 14 - Revised syllabus July 2022
Engineering trades under CTS

Duration: 1 Year

CTS Trades Covered: Rubber Technician

S.no.	Syllabus	Time in Hrs
1	Introduction to Engineering Drawing and Drawing Instruments – <ul style="list-style-type: none">• Conventions• Sizes and layout of drawing sheets• Title Block, its position and content• Drawing Instruments	2
2	Free hand drawing of - <ul style="list-style-type: none">• Geometrical figures and blocks with dimension• Transferring measurement from the given object to the free hand sketches.• Free hand drawing of hand tools and measuring tools.	6
3	Drawing of Geometrical figures: <ul style="list-style-type: none">• Angle, Triangle, Circle, Rectangle, Square, Parallelogram.• Lettering & Numbering - Single Stroke.	10
4	Reading of dimension and Dimensioning Practice <ul style="list-style-type: none">• Reading of dimension and Dimensioning Practice	4
5	Symbolic representation - <ul style="list-style-type: none">• Different symbols used in the related trades.	8
6	Reading of Job/ process drawing related to Rubber Technician trade.	10
	Total	40

Introduction to engineering drawing and drawing instruments

Communication

There are many different ways of communicating ideas, information, instructions, requests, etc. They can be transmitted by signs or gestures, by word of mouth, in writing, or graphically. In an industrial context the graphical method is commonly used with communication is achieved by means of engineering drawings.

If oral and written communication only were used when dealing with technical matters, misunderstandings could arise, particularly in relation to shape and size. The lack of a universal spoken language makes communication and understanding even more difficult because of the necessity to translate both words and meaning from one language to another.

However, the universally accepted methods used in graphical communication through engineering drawings eliminate many of these difficulties and make it possible for drawing prepared by a British designer to be correctly interpreted or "read" by, for example, his German, French or Dutch counterparts.

Equally important, the components shown on the drawings could be made by suitably skilled craftsmen of any nationality provided they can "read" an engineering drawing.

Conventionally prepared engineering drawings provide the main means of communication between the "ideas" men (the designers and draughtsman) and the craftsmen (machinists, fitters, assemblers, etc.). For the communication to be effective, everyone concerned must interpret the drawing in the same way. Only then will the finished product be exactly as the designer envisages it.

To ensure uniformity of interpretation, the British Standards Institution has prepared a booklet entitled BS 308:1972, Engineering Drawing Practice. Now in three parts, this publication recommends the methods which should be adopted for the preparation of drawing used in the engineering industry.

The standards and conventions in most common use and hence those required for a basic understanding of engineering drawing are illustrated and explained in this book.

Language

1 It is the media of communication (Fig 1)

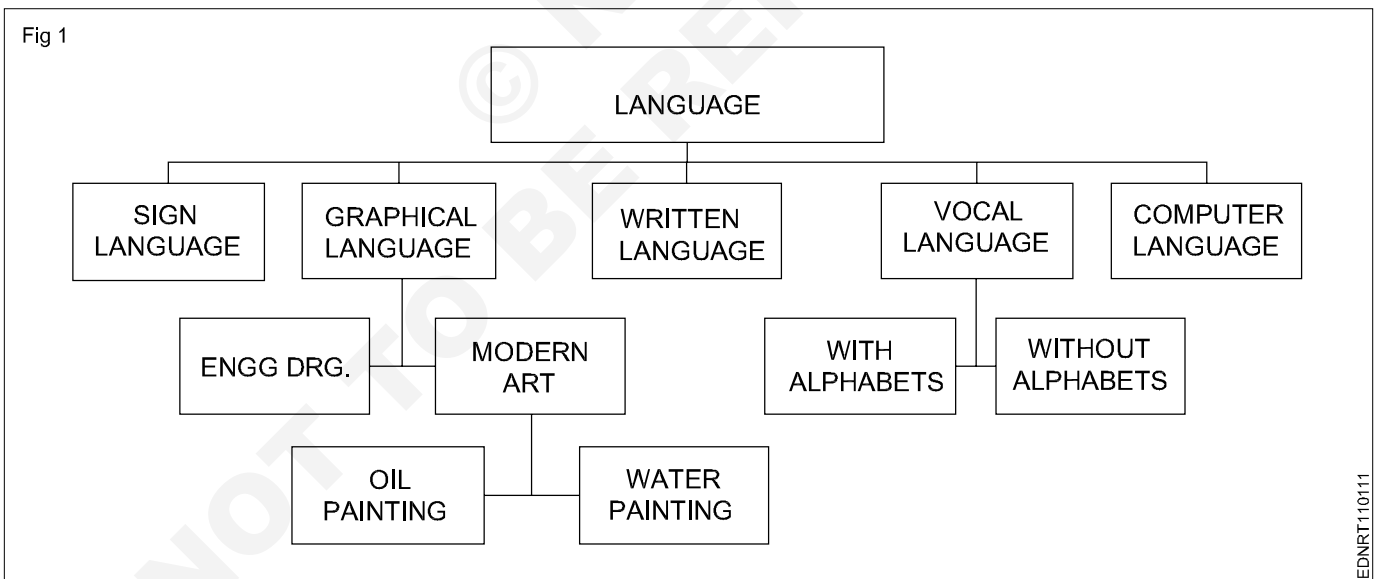

Conclusion

Effective communication is possible when graphical language is supported by written language/vocal language and vice versa.

Engineering drawing is a language that uses both graphical language and written language for effective communication.

Engineering drawing is a graphical language that also uses written language for effective communication.

The importance of Engineering Drawing

The economic success of any country is mainly dependent on its industrial development. Due to globalization, any industry in our country is expected to be of a global market standard. For the above-mentioned reasons, our Indian products require very high quality for their size, dimension, fit, tolerance, and finish etc.

To produce the best standard product, all the technical personnel (Engineers to Craftsman) in an industry must have a sound knowledge of engineering drawing because engineering drawing is the language of engineers. Engineering drawing is a universal language. Different types of lines make up their alphabets. Technical personnel in any industry, including craftsman, are expected to communicate anything concerning a part or a component by means of drawings involving lines, symbols, conventions, abbreviations etc.

With our spoken languages, it is impossible to express the details of a job or a product. Engineering drawing knowledge and practise are a must for designing or producing a component or part. Even a small mistake in the drawing may reflect very badly on the product. Therefore, reading and doing engineering drawings are very essential for craftsmen and engineers.

A drawing is a graphical representation of an object, or part of it, and is the result of creative thought by an engineer or technician. When one person sketches a rough map in giving direction to another, this is graphic communication. Graphic communication involves using visual materials to relate ideas. Drawings, photographs, slides, transparencies, and sketches are all forms of graphic communication. Any medium that uses a graphic image to aid in conveying a message, instructions, or an idea is involved in graphic communication.

One of the most widely used forms of graphic communication is the drawing. Technically, it can be defined as **"a graphic representation of an idea, a concept or an entity which actually or potentially exists in life"**

Drawing is one of the oldest forms of communicating, dating back even farther than verbal communication. The drawing itself is a method of communicating necessary information about an abstract, such as an idea or concept or a graphic representation of some real entity, such as a machine part, house or tools. There are two basic types of drawings: Artistic and Technical drawings.

Technical drawings

Technical drawings allows efficient communication among engineers and can be kept as a record of the planning process. Since a picture is worth a thousand words, a technical drawing is a much more effective tool for engineers than a written plan.

The technical drawing, on the other hand is not subtle, or abstract. It does not require an understanding of its creator, only on understanding of technical drawings. A technical drawing is a means of clearly and concisely communicating all of the information necessary to transform an idea or a concept in to reality. Therefore, a technical drawing often contains more than just a graphic representation of its subject. It also contains dimensions, notes and specifications.

Fields of use

Technical drawing is the preferred method of drafting in all engineering fields, including, but not limited to, civil engineering, electrical engineering, mechanical engineering and architecture.

Purpose of studying engineering drawing

- 1 To develop the ability to produce simple engineering drawing and sketches based on current practice
- 2 To develop the skills to read manufacturing and construction drawings used in industry.
- 3 To develop a working knowledge of the layout of plant and equipment.
- 4 To develop skills in abstracting information from calculation sheets and schematic diagrams to produce working drawings for manufacturers, installers and fabricators.

Main types of Engineering drawing

Regardless of branch of engineering the engineering drawing is used. However based on the major engineering branches, engineering drawing can be classified as follows: (Fig 2)

Mechanical engineering drawings

Some examples of mechanical engineering drawings are part and assembly drawings, riveted joints, welded joints, fabrication drawings, pneumatics and hydraulics drawings, pipeline diagrams, keys coupling drawings etc. (Fig 3&4)

Electrical Engineering drawing

Wiring diagrams of home and industries, circuit diagrams, electrical installation drawings etc.

Example

The voltage supply to a filament lamp is 10.8V. The voltage should be 12V. (Fig 5)

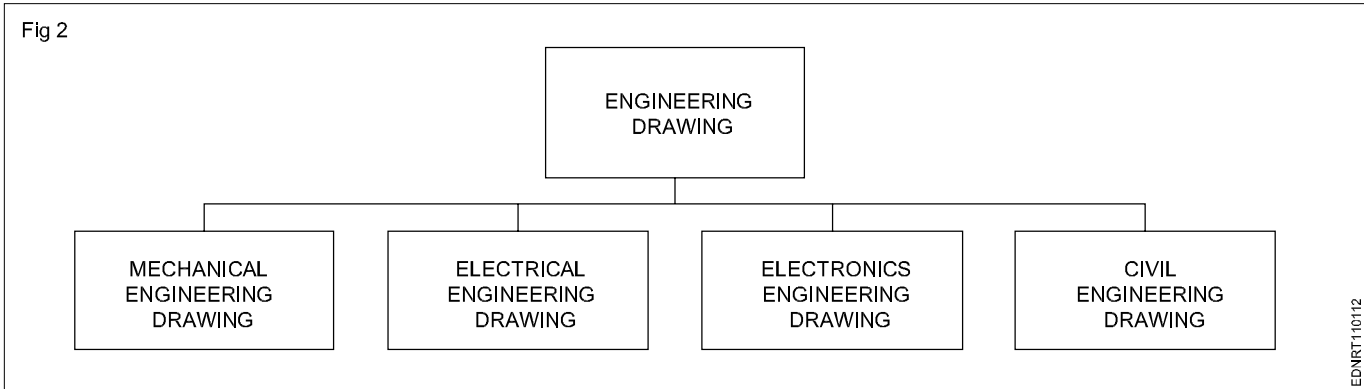

Mechanical engineering drawings (Fig 3&4)

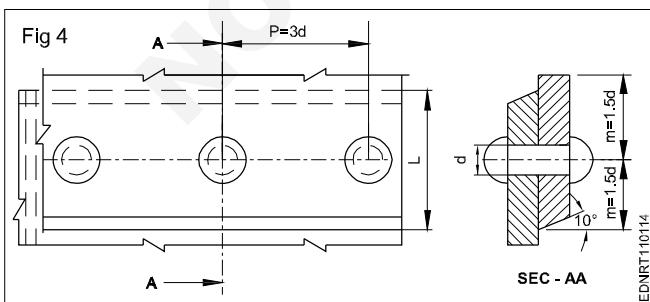
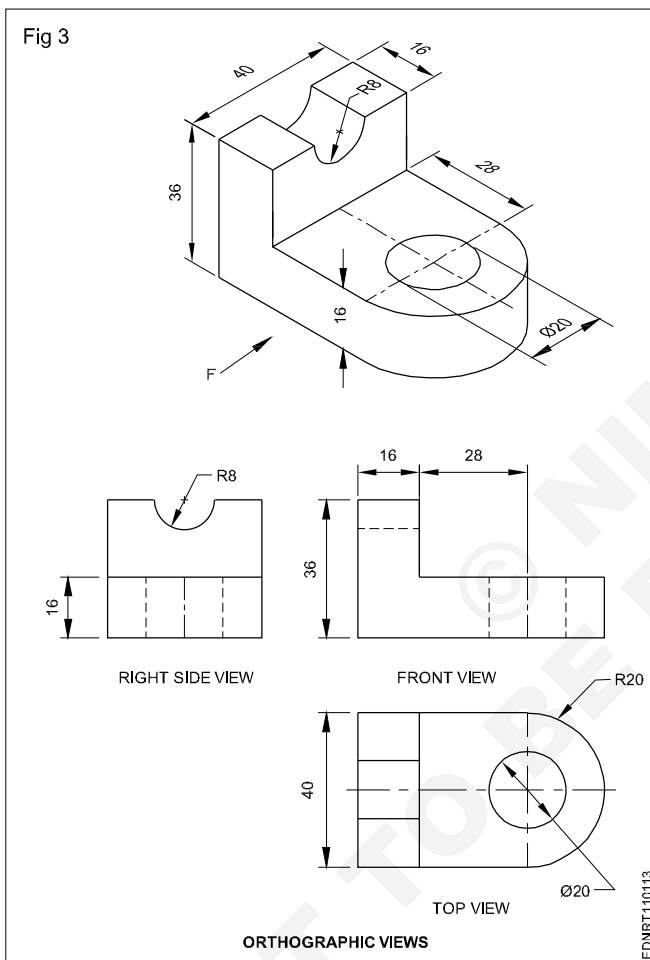

Electrical Engineering drawing (Fig 5)

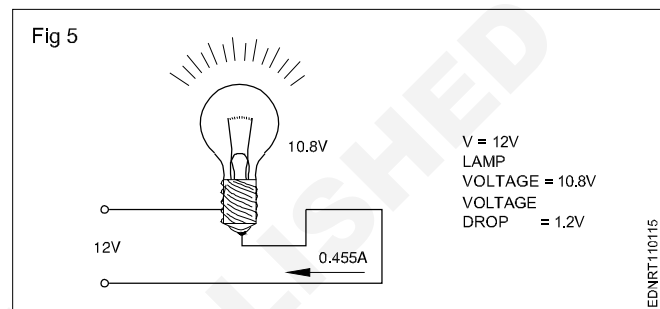

Electronics Engineering drawing

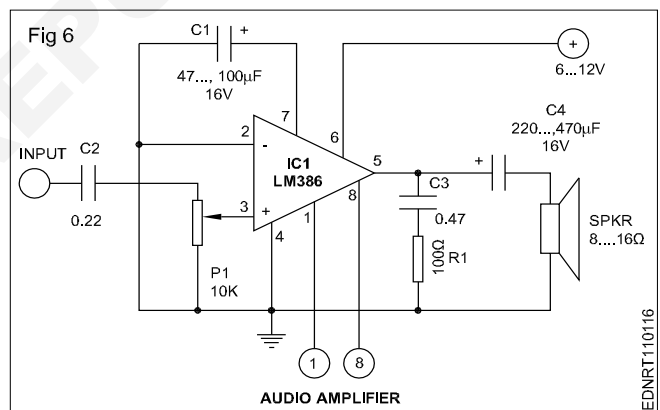

Audio amplifier (Fig 6)

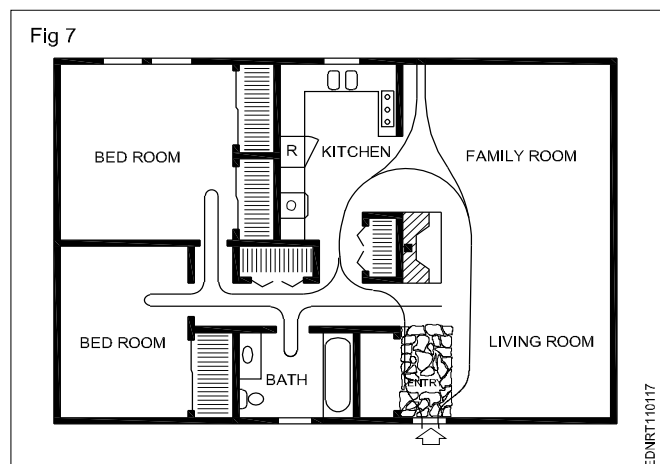

Civil Engineering drawing (Fig 7)

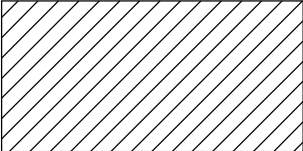
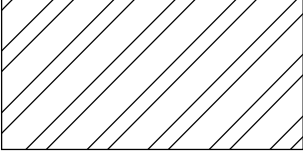
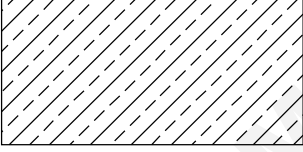

Conventions

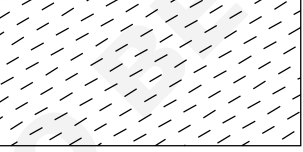
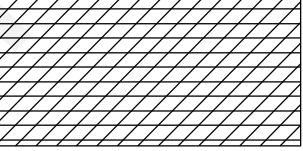
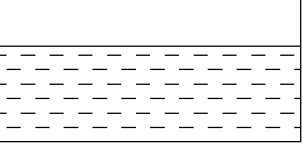
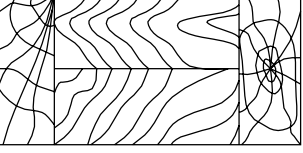
TYPE	CONVENTION	MATERIALS
Metals		Steel, Cast Iron, Copper and its Alloys, Aluminium and its alloy, etc
		Lead, Zinc, Tin, White-metal, etc.
Glass		Glass
Packing and Insulating materials		Porcelain, Stoneware, Marble, Slate etc
		Asbestos, Fibre, Felt, Synthetic resin products, Paper, Cork, Linoleum, Rubber, Leather, Wax, insulating & Filling Materials etc
Liquid		Water, Oil, Petrol, Kerosene etc
Wood		Wood, Plywood etc
Concrete		Concrete

Sizes and layout of drawing sheets

Size of drawing sheets (in mm): While being worked on or handled, the drawing sheets are prone to tear along the edges. So slightly larger (untrimmed) sheets are preferred. They are trimmed afterwards. IS:10811:1983 lays down such as designation of preferred trimmed and untrimmed sizes.

Designation of sheets: The drawing sheets are designated by symbols such as A0, A1, A2, A3, A4 and A5. A0 being the largest and A5 is smallest. Table 1 below gives the length and breadth of the above sizes of sheets. (Trimmed and untrimmed)

The relationship between two sides is same as that between a side of a square and its diagonal.

TABLE 1

Designation	Trimmed size	Untrimmed size
A0	841 x 1189	880 x 1230
A1	594 x 841	625 x 880
A2	420 x 594	450 x 625
A3	297 x 420	330 x 450
A4	210 x 297	240 x 330
A5	148 x 210	165 x 240

Special elongated series increasing its widths, double, treble etc. are denoted as follows A3 x 3, A3 x 4, A4 x 3, A4 x 4, A4 x 5. Please refer Table 2.

TABLE 2

Special elongated series

Designation	Size
A3 x 3	420 x 891
A3 x 4	420 x 1189
A4 x 3	297 x 630
A4 x 4	297 x 841
A4 x 5	297 x 1051

Fig 1 & 2 shows how the sheet sizes are formed by halving/doubling and similarity of format.

White drawing papers that do not turn yellow on exposure to air are used for finished drawings, maps, charts and drawings for photographic reproductions.

For pencil layouts and working drawings, cream-coloured papers are best suited.

Quality drawing paper: The drawing papers should have sufficient teeth or grain to take the pencil lines and withstand repeated erasing.

To get uniform lines, backing paper is to be placed on the drawing board before fixing drawing/tracing paper. Before starting the drawing, the layout should be drawn. (Ref: IS:10711)

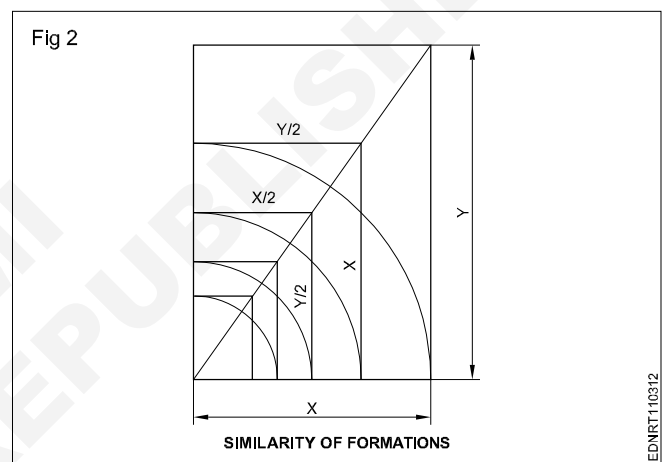
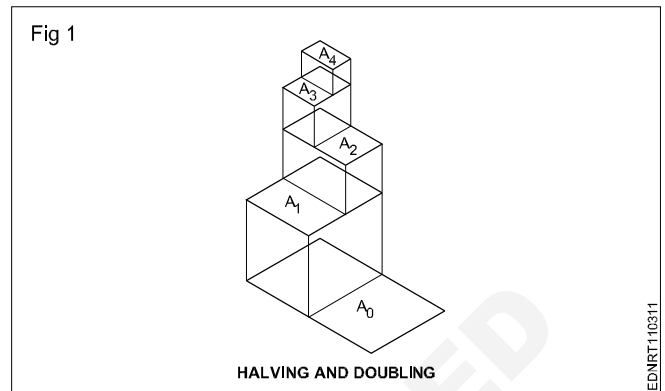

The following is the method of folding printed drawing sheets as recommended by BIS. (Fig 3)

Method of folding of printed drawing sheets as per BIS SP: 46-2003

When drawings sheets are in more numbers, they have to be folded and kept in order to save the trace required for preserving them (Fig 4).

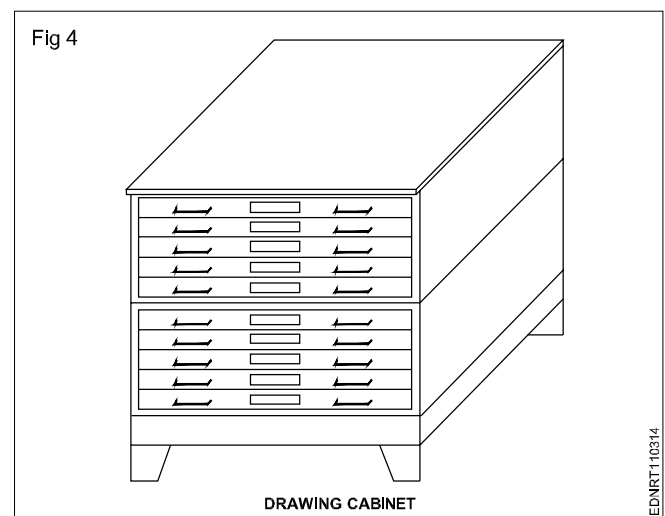

EDNRT110311

EDNRT110312

EDNRT110314

Method of folding printed drawing sheets (Fig 3)

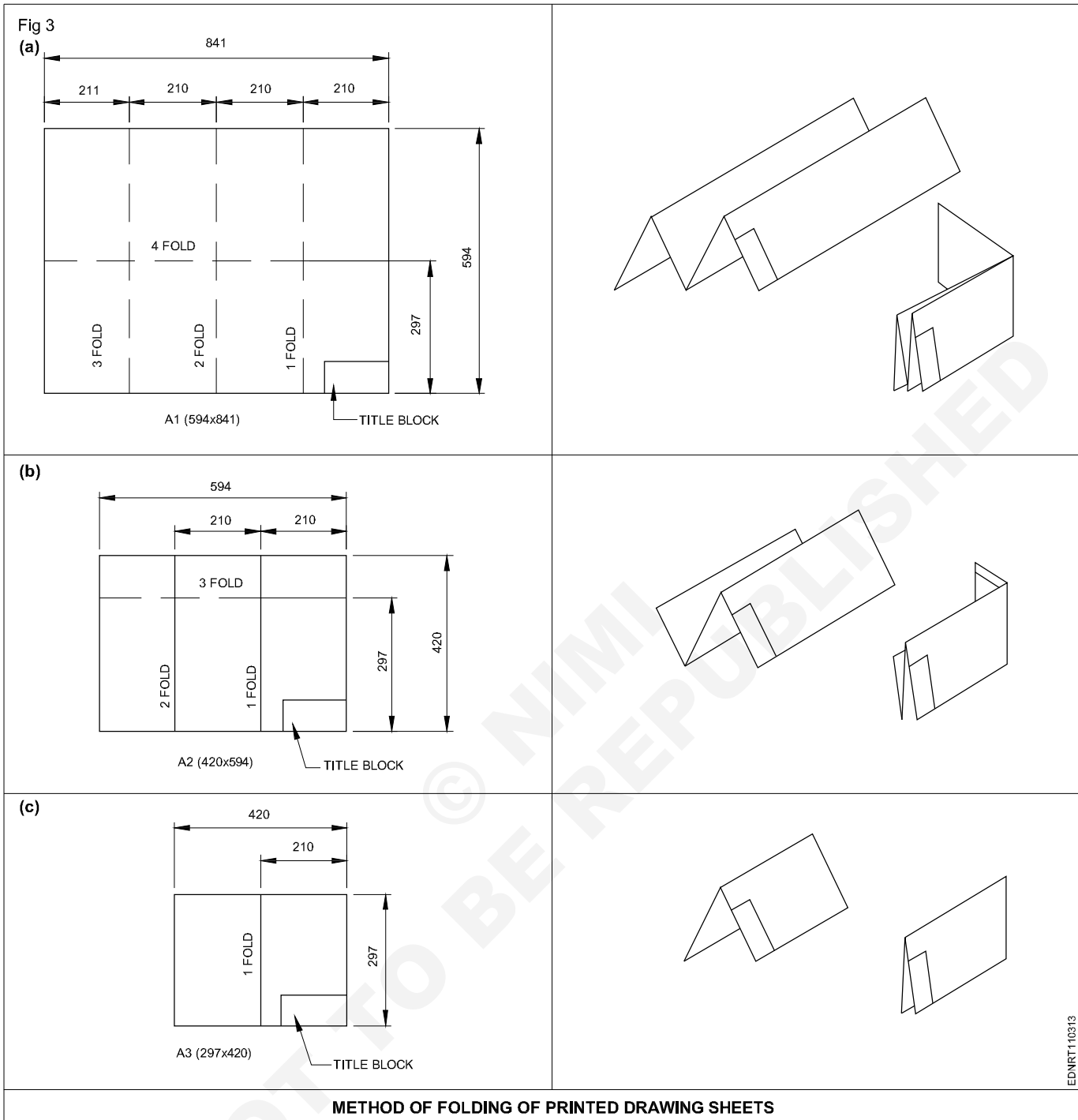

Title block, its position and content

Layout of drawing sheet

As a standard practice, sufficient margins are to be provided on all sides of the drawing sheet. The drawing sheet should have drawing space and title space. A typical layout of a drawing sheet is shown in the (Fig 1 & 2).

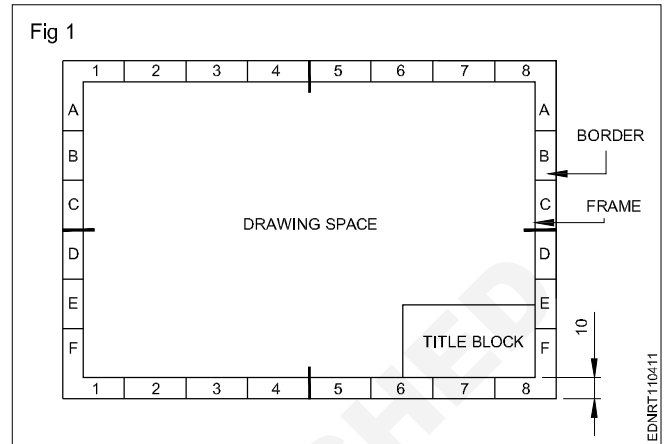

Title Block - 1

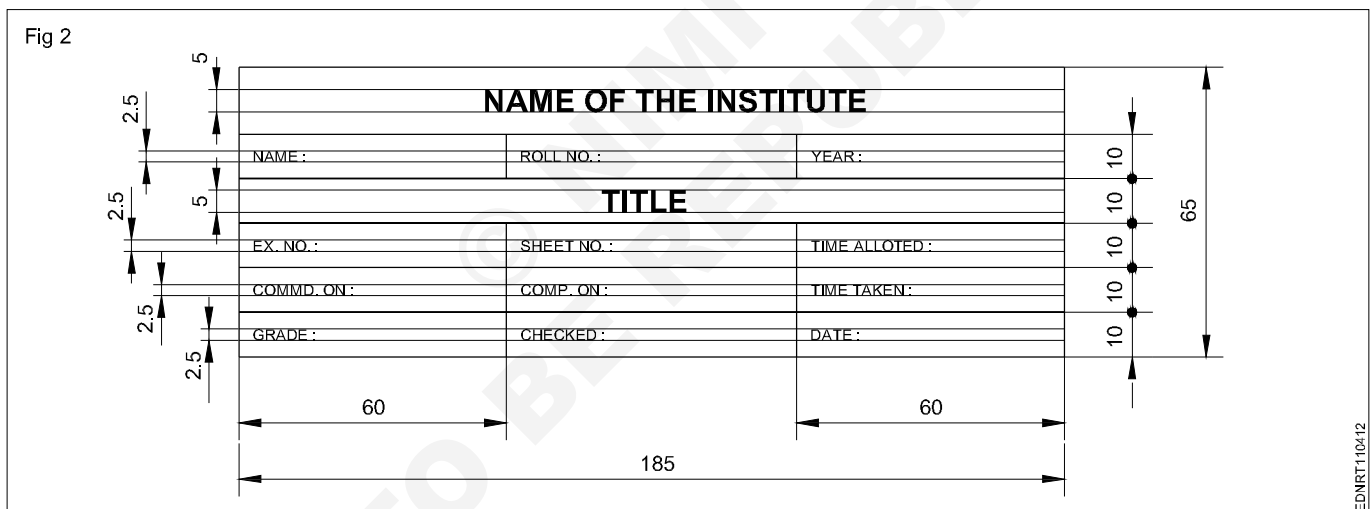

Title Block - 2

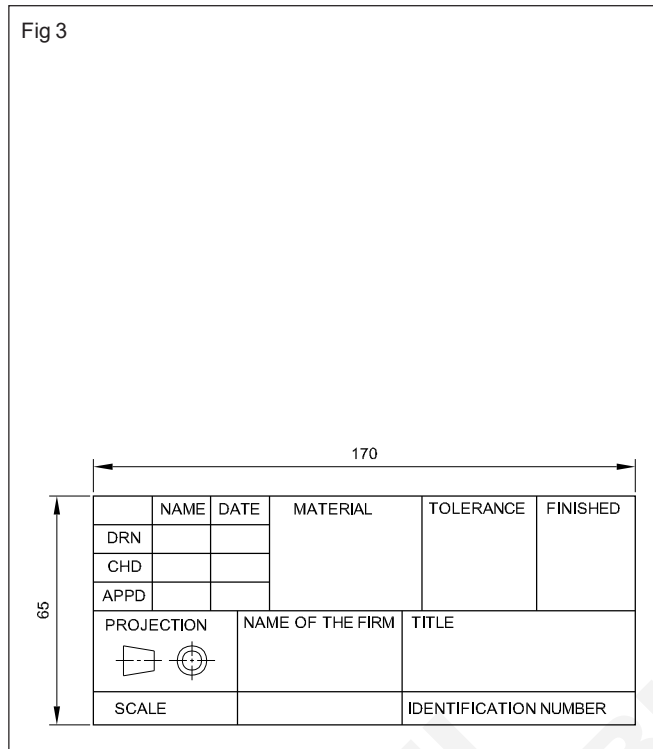

Title Block - 3

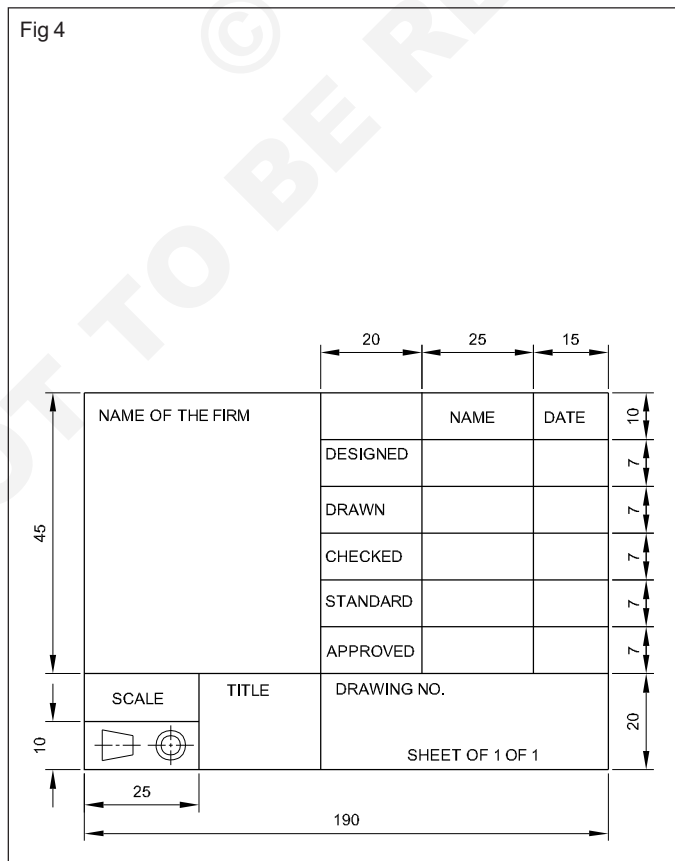

Title Block - Position and content - 1

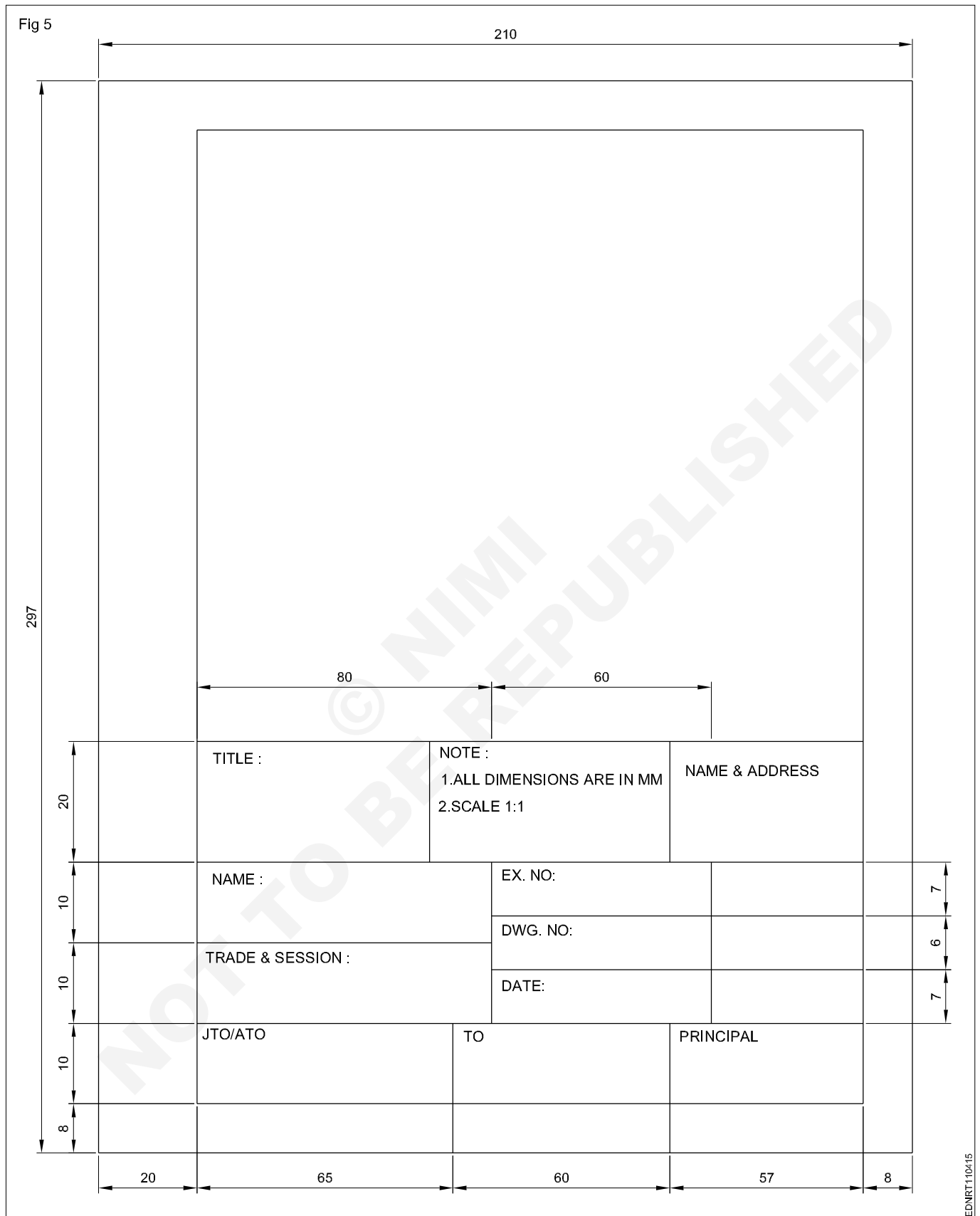

Title Block - Position and content - 2

Fig 6

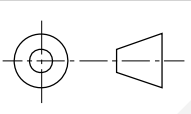
DO NOT SCALE		REVISION			
SL.N	DESCRIPTION	DATE	APPX		
A	M12 WAS ½ WHIT.	14.12.18	A.W.D		
UNLES OTHERWISE STATED ALL DIMENSIONS IN MILLIMETRES. TOLERANCES LINEAR: ANGULAR:				DRN 1:1:78 JKL	(NAME OD THE FIRM)
		MATERIAL : CAST STEEL		CKD 2:1:78 MLN	
DRAFTING STANDARD AS 1100		FINISH AS MACHINED		APPD 5:1:78 AWB	(TITLE OF DRW.)
				ISSUED 4:2:78 PFP	
				SIZE A3	DRG NO A24641
		SCALE 1:2	SHEET 1 OF 1		

Item Reference on Drawing Sheet

05	TIGHTENING PIN	01	MILD STEEL	
04	WORKPIECE	01	ANY MATL.	
03	SCREW ROD	01	STD.	
02	"U" CLAMP	01	CAST IRON	
01	"V" BLOCK	01	CAST IRON	
PART NO	DESCRIPTION OF ITEM	QTY/ASSY	MATERIAL	REMARKS
BILL OF MATERIALS				

The drawing sheet on which the drawings to be prepared should be prepared first by following the procedure given below:

- 1 Take A4/A3 drawing sheet.
- 2 Mark the borders and draw the title block as mentioned.

- 3 Follow the same procedure for A3 drawing sheet where the title block is to be drawn right side bottom corner and the border dimensions remain same.
- 4 Title block to be drawn whenever the title of the drawing changes. Eg. for the geometrical construction chapter the title block may be drawn in the first sheet only where as on the remaining sheets borders to be drawn before they are used for preparing drawings.

Drawing instruments

The following are the commonly used equipment in a drawing office.

Drawing board (Fig 1): Drawing board is one of the main item of equipment for Draughtsman. It is used for supporting the drawing paper/tracing paper for making drawings. It is made of well-seasoned wood strips of about 25 mm thick or masonite, free from knots and warping. It should be softer enough to allow insertion and removal of drawing pins. Two battens are fastened to the board by screws, in slotted joints. They prevent warping and at the same time permit expansion and contraction of the strips due to the change of moisture in the atmosphere.

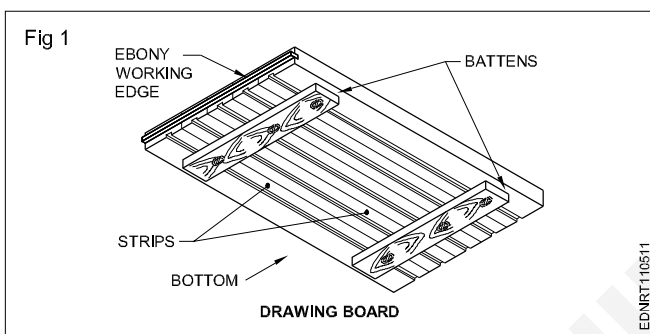

One of the shorter edges of the drawing board is provided with an "ebony edge" (hardwood) fitted perfectly straight.

Standard drawing boards are designated as follows as per IS:1444-1989.

Sl. No.	Designation	Size (mm)
1	D0	1500 x 1000 x 25
2	D1	1000 x 700 x 25
3	D2	700 x 500 x 15
4	D3	500 x 350 x 15

The working edge (ebony) must be straight.

Now-a-days drawing boards are available with laminated surfaces. The flatness can be checked by placing a straight edge on its surface. If no light passes between them, the surface is perfectly flat.

'T' Square: It is of 'T' shape, made of well-seasoned wood. It has two parts., head/stock and blade. One of the edges of the blade is the working edge. The blade is screwed to this head such that the working edge is at a right angle to the head. (Fig 2a)

The standard 'T' square is designated as follows with dimensions shown in mm; as per IS:1360-1989.

Sl. No.	Designation	Blade length
1	T0	1500
2	T1	1000
3	T2	700
4	T3	500

The 'T' square is used with its head against the ebony edge of the drawing board to draw horizontal lines, and parallel lines and to guide/hold the set squares, stencils etc.

Fig 2b shows how the 'T' square is used.

'T' square should never be used as a hammer or as a guide for trimming papers.

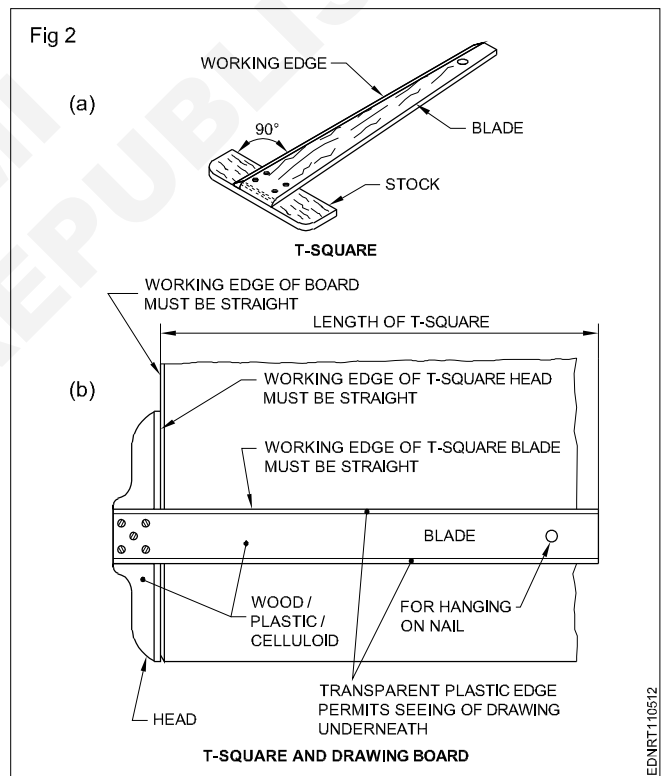

Drafting in the machine (Fig 3): It serves the functions of a Tee square, set square, protractor and scale. They come in different sizes and have a pattern called the 'Pantograph' type. It is fitted on the top left side, edge of the drafting board, mounted on an adjustable frame or table. It requires a large area of working place. The angle of the drafting board can be adjusted by the pedal operating system. There are two counterweights to balance the angular position of the board and the drafting head. It is more suitable for the production drawing office.

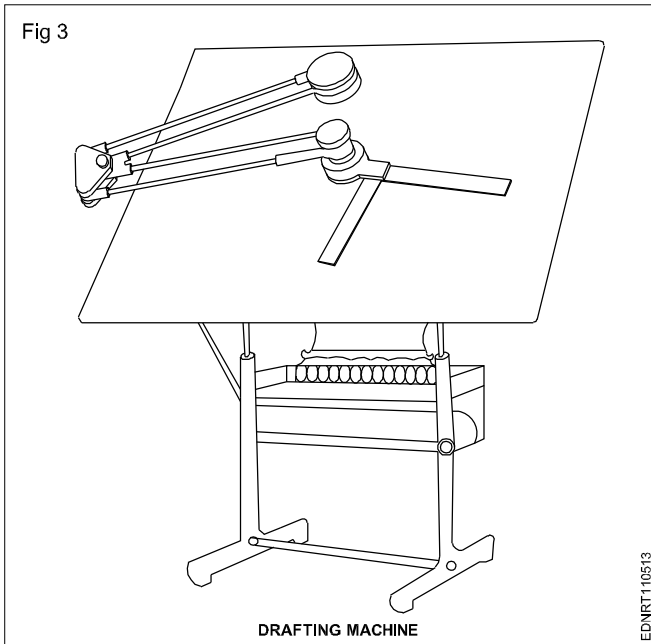

On the other end, a protractor head H with swivelling and locking arrangement is fitted with two scales at right angles.

The protractor head has a spring-loaded clutch relieving handle, which rotates and locks at 15° intervals automatically. For setting any angle other than multiples of 15°, the clutch spring is released and by rotating the centre knob, the zero line is set to the required angle and the friction clutch knob is tightened. It is capable of rotating 180°, thereby any angle can be set.

The scales are bevelled on both sides, graduates to 1:1 & 1:2. They can be reversed with the help of dovetail slide fitting.

There is a fine adjusting mechanism on the drafting head to set the scale parallel to the edge of the board. The scales also can be adjusted if there is an error in measuring 90° between them.

The mini drafter is an important device used for making drawing quickly & accurately. This instrument has the combination of T-square, set square, protractor and scales, it helps to draw the drawings at a faster rate. (Fig 4,5 & 6)

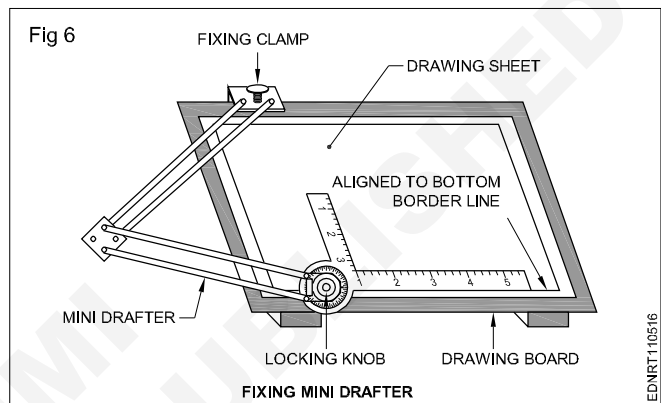
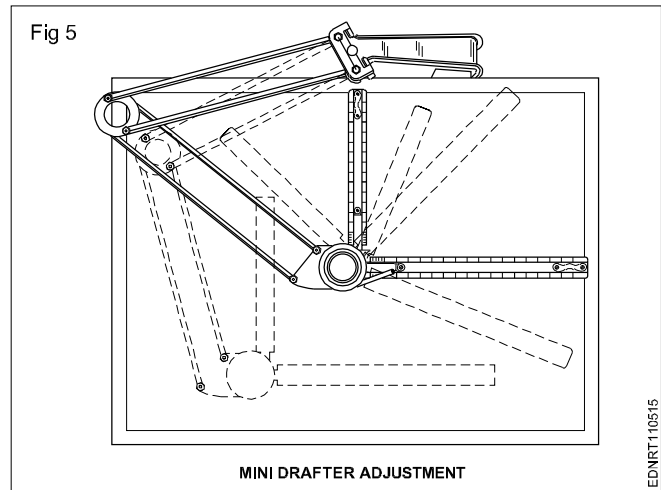
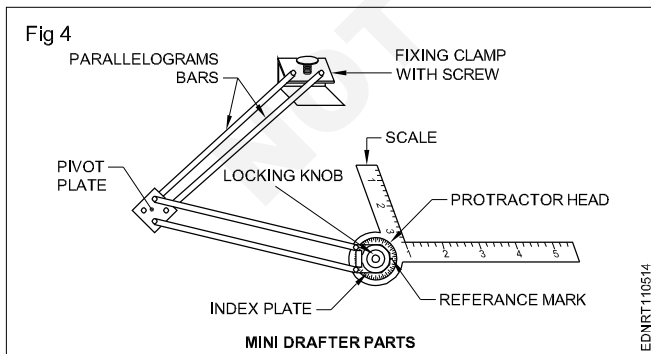

Erasing shield: When, on a drawing, if a part of a line or some lines among many other lines needs to be erased or modified, in a normal way erasing will damage the other nearby lines. In such a situation an erasing shield is effectively useful. It is a thin metallic sheet having small openings of different sizes and shapes. A suitable opening is aligned to the line to be erased and the line is removed by the eraser. (Fig 7)

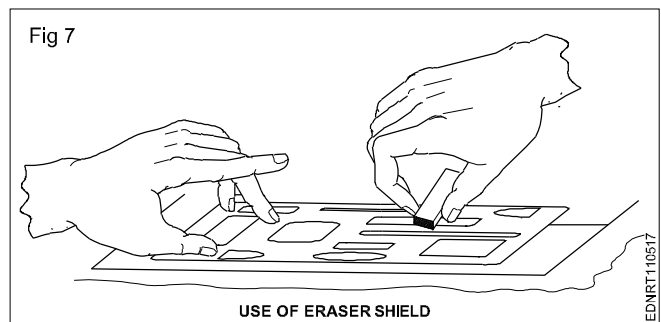

Set square (IS:1361-1988): Transparent celluloid/Plastic set squares are preferred and are commonly used rather than ebonite ones. They are two in number, each having one corner with 90°. The set square with 60° & 30° of 250 mm long and 45° of 200mm long is convenient for use. (Fig 8)

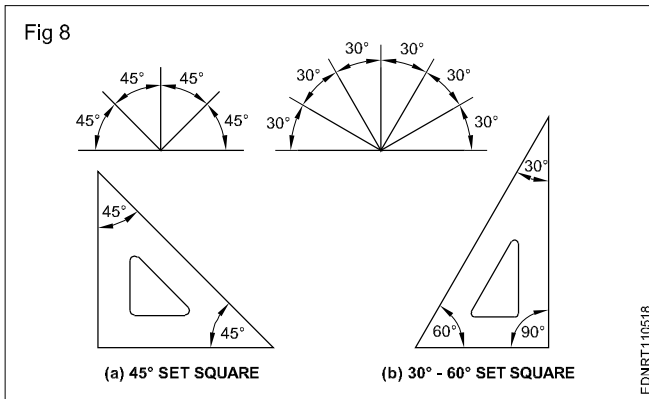

Scales: Scales are used to transfer and or measure the dimensions. They are made of wood, steel, ivory, celluloid or plastic, stainless steel scales are more durable. different types of scales used are shown in Fig 9. They are either flat, bevel-edged or triangular cross-sections. Scales of 15cm long, 2cm wide or 30cm long 3.5cm wide are in general use.

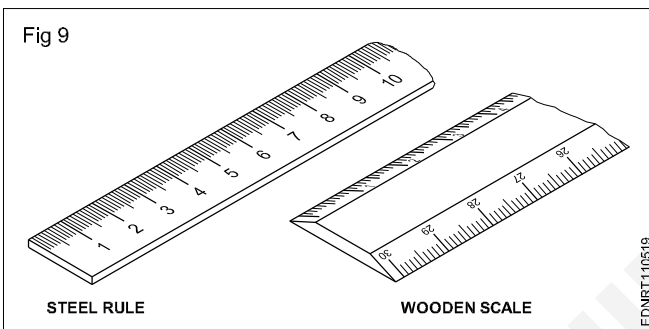

Protractor: A protractor is an instrument for measuring angles. It is semi-circular or circular and is made of a flat celluloid sheet.

The angles can be set or measured from both sides, aligning the reference line and point '0' with the corner point of the angle.

Figure 10 shows how to read or set the angle. A protractor can also be used to divide a circle or draw sectors.

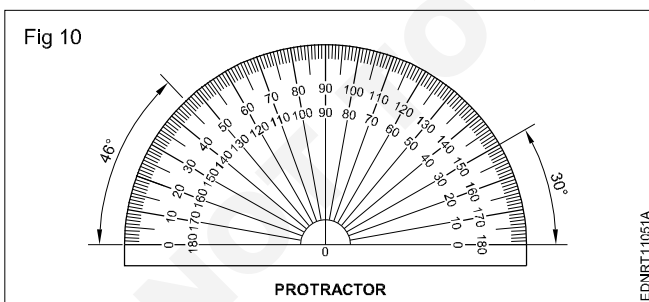

French curves (Fig 11)

These are made in many different shapes, normally come in sets of 6, 12, 16 etc. French curves are best suited to draw smooth curves/arcs (which cannot be drawn by a compass) with ease. To draw a smooth curve using a french curve first set it by trial against a part of the line to be drawn, then shift it to the next portions.

Fig 12 shows how to use the french curve and draw smooth curves. They are made of transparent celluloid (no bevel edge).

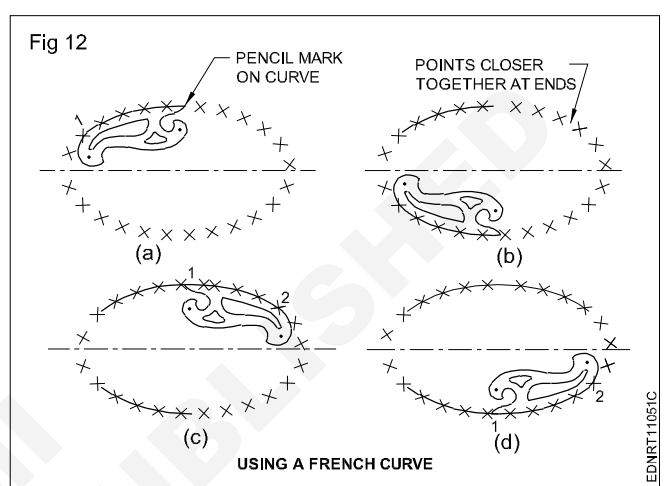
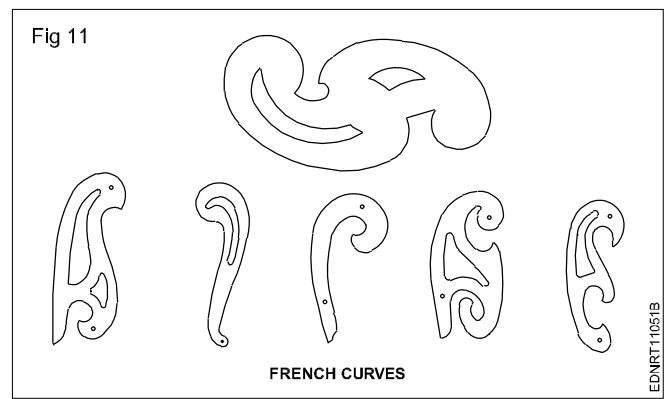

An instrument box contains the following: (Fig 13a to h)

- Large compass (with attachment facility) (a)
- Large divider (b)
- Bow compasses(pencil/ink), bow divider (c)
- Lengthening bar (d)
- Pen point for attachment (e)
- Screwdriver (f)
- Lead case (g)
- Liner (h)

Large compass (Fig 14): It has a knee joint in one leg that permits the insertion of a pen or pencil point or attaching a lengthening bar with a pen or pencil point attached to it. It is used for drawing large circles/arcs and also for taking large measurements.

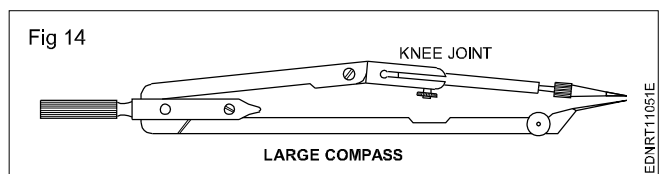

As a rule, while drawing concentric circles, small circles should be drawn first before the centre hole gets worn.

Large divider: It is used to transfer dimensions and divide lines into several equal parts. Divider with adjustable joints is preferable rather than plain legs. (Fig 15)

Fig 13

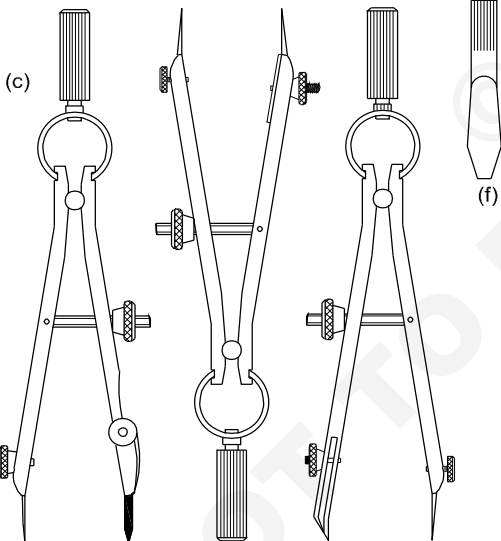
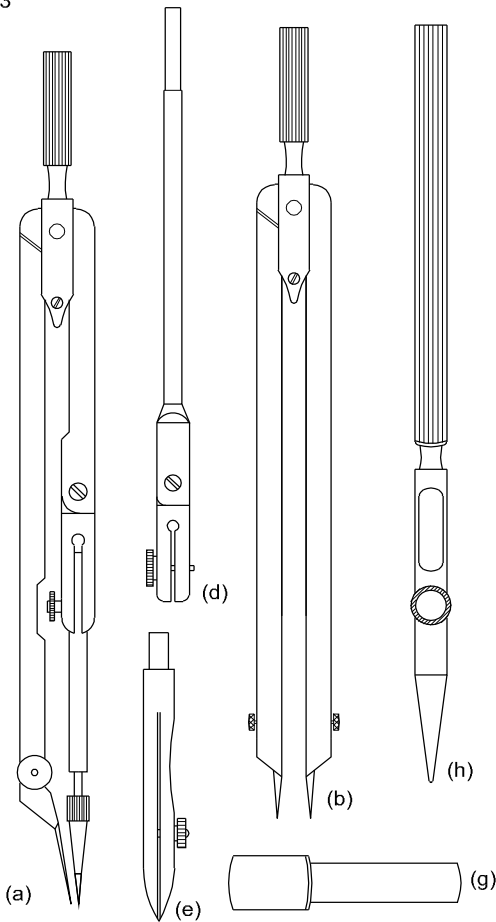

DRAWING INSTRUMENTS

EDNRT11051D

Fig 15

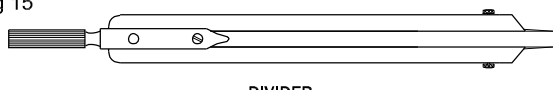

DIVIDER

EDNRT11051F

Bow instruments: Bow pencil and bow pen compass are used for drawing circles of approximately 25 mm radius. A bow divider is used for marking or dividing smaller spaces. There are two types (i) Integral legs with spring action (ii) two legs are held with a curved spring on top with a handle on it.

Fig 16 shows different types of bow instruments. Adjustments should be made with the thumb and middle finger.

Fig 16

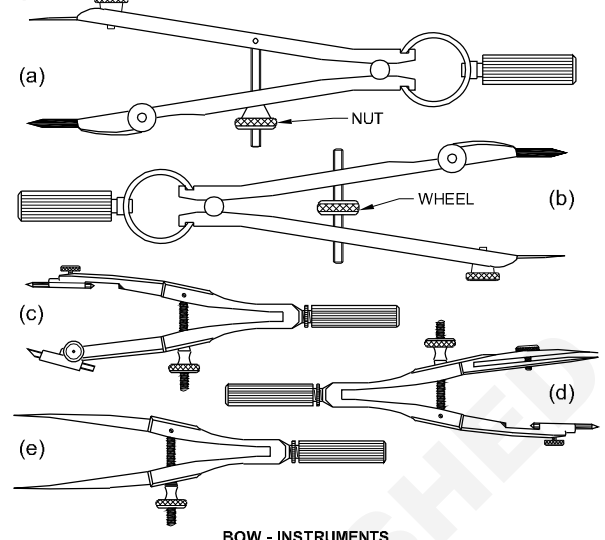

BOW - INSTRUMENTS

EDNRT11051G

Drop spring bow pencil and pen (Fig 17): Drop spring bow pencil and pen are designed for drawing multiple identical small circles. Example: rivet holes, drilled/reamed holes. The central pin is made to move freely up and down through the tube attached to the pen or pencil unit.

Fig 17

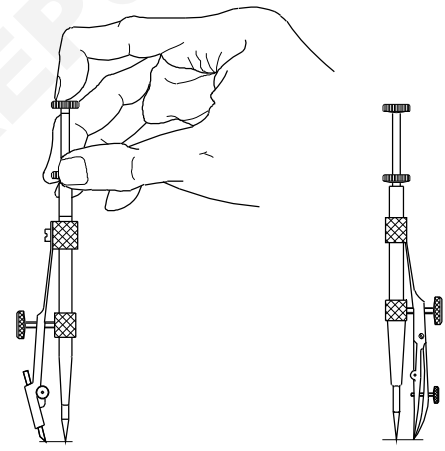

DROP SPRING BOW PENCIL

DROP SPRING BOW PEN

DROP SPRING BOW INSTRUMENT

EDNRT11051H

Inking pen or liner or ruling pen (Fig 18): It is used to ink the straight lines drawn with the instruments but never for freehand lines or lettering.

Fig 18

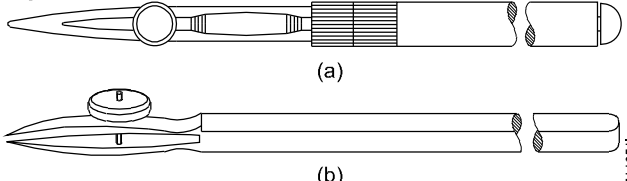

(a)

(b)

RULING PENS

EDNRT11051I

Lengthening bar (Fig 19): To draw larger circles, it is fitted to the compass. The pencil point or pen point is inserted into its end.

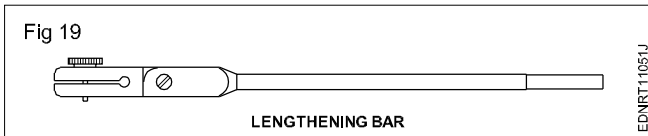

Replaceable spare pencils, pens and needle points for the compass are available in the instrument box.

Screwdriver (Fig 20): Used for adjusting the screws of the instruments.

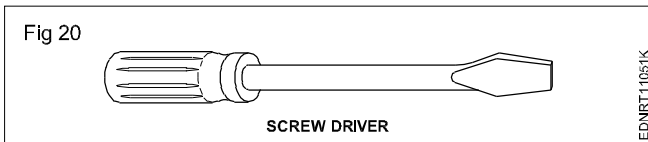

Lead case (Fig 21): Lead case is the box for holding the pencil leads.

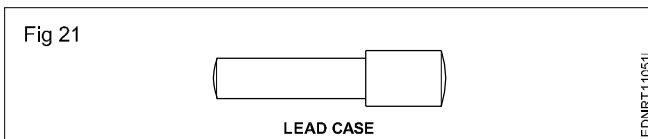

Pin, Clip, Cello tape: Drawing sheet should be fastened onto the drawing board firmly temporarily so that it does not shake during preparing the drawing. For this purpose, the pins, clips and cello tapes are used (Fig 22)

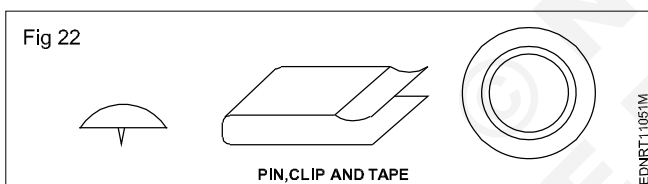

Pencils, Grade and Selection (Fig 23)

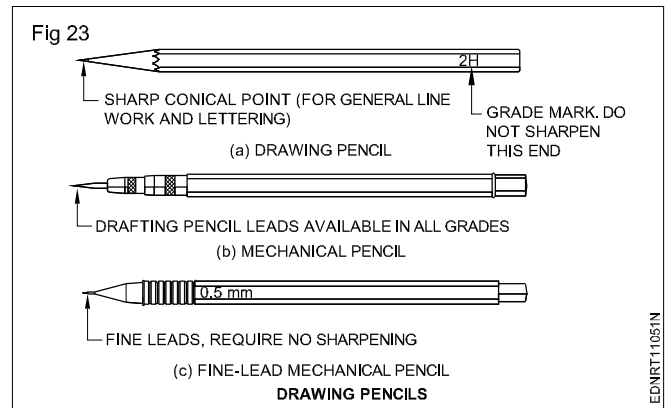

Grades of pencils: Pencils are graded according to the hardness or softness of the lead.

The hardest pencil is 9H grade and the softest pencil is 7B grade. The selection of the grade of pencils depends on the type of line work required and the paper on which it is used.

Softer lead pencils are used to produce thicker and darker line work, but they wear out quickly. Medium grades of H and 2H are used for general line work as well as for lettering.

Selection of pencils: Pencil grades vary from one brand to another brand. Select the grades of the pencil depending upon the type of line work. For construction lines, you can choose 2H or 3H, for lettering and object lines grade H pencils. In general H, HB and 2H are used.

H - medium-hard

HB - medium-soft

2H - hard

Now-a-days automatic (Mechanical) pencils or clutch pencils are available in different sizes (lead dia. 0.3, 0.5, 0.7 or 0.9). Leads can be replaced as per the required grade of hardness. They produce lines of uniform width without sharpening.

Free hand drawing of - Geometrical figures and blocks with dimension

Freehand sketching: Apart from making drawing using instruments, often craftsmen will be required to make drawings with their free hand.

Freehand sketching is the easiest method to express the shape of a piece part or a component by an engineer or craftsman.

Freehand sketches are not usually made to scale. However, they should be as nearly to the proportions as possible.

Cube (Fig 1)

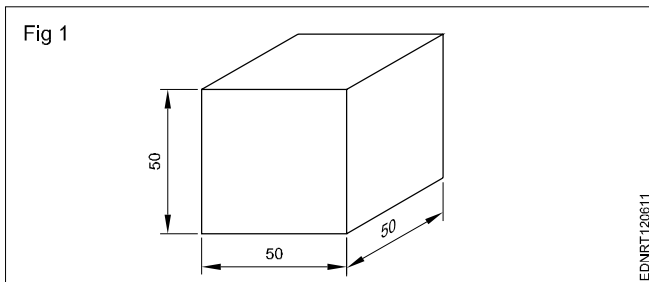

Square block (Fig 2)

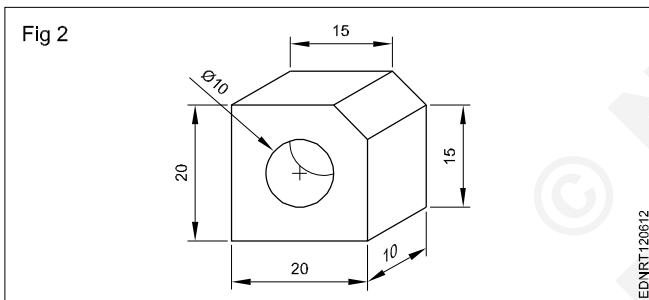

Rectangular block (Fig 3)

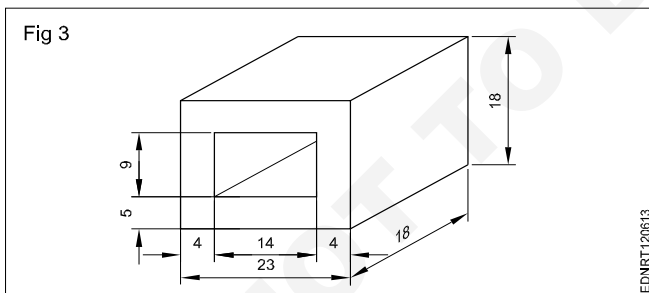

Cube block (Fig 4)

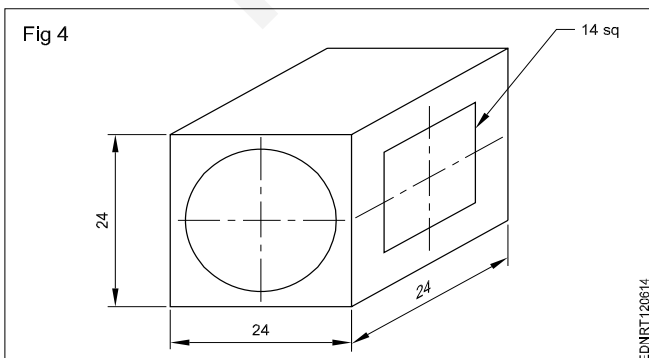

Cylinder (Fig 5)

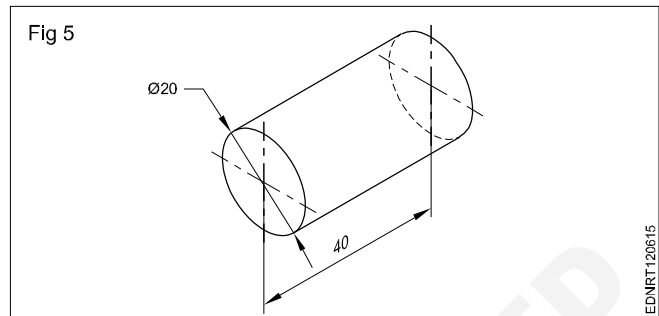

Materials for free hand sketching: A4 size sheet (preferably a pad instead of loose papers) pencils of soft grade. Example H, HB, and a good quality eraser are the only materials required. For drawing different darkness, the pencil points should be sharpened to a conical shape. Fig 6 shows some free hand sketches of different types of views.

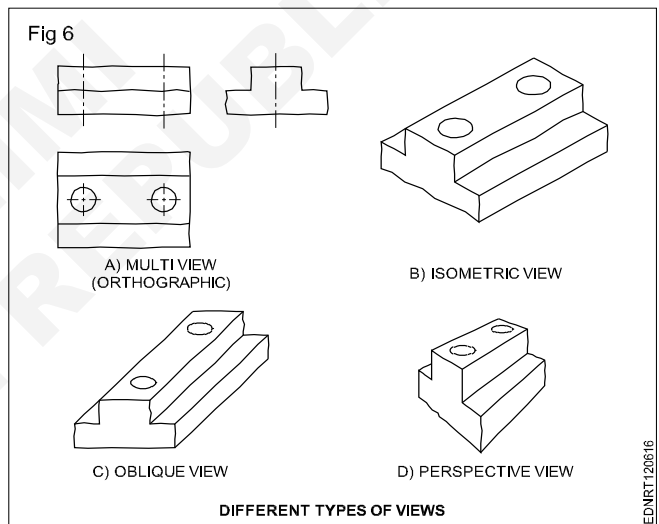

Procedure

Freehand drawing of solid figures, cubes, cuboids, cone, prism, pyramid, frustum of a cone with dimensions

Cube (Fig 1)

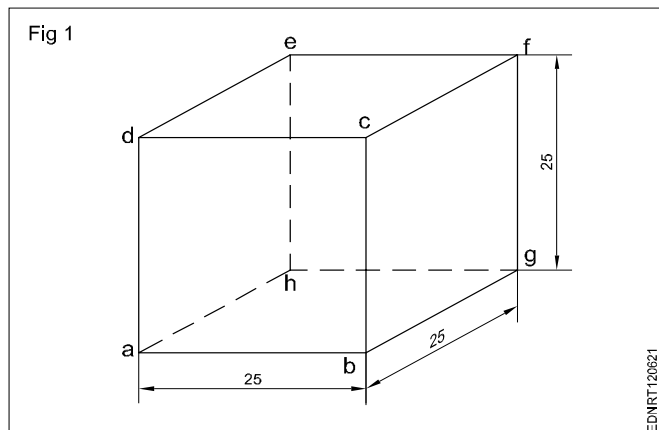

- Draw squares of a, b, c and d.
- Draw 30° from points b, c and d for the length of 25mm.
- Mark point g from b, f from c and e from d as shown in the figure.
- Joint all points.

Cuboid (Fig 2)

Draw the isometric drawing of a cuboid of base 60 mm x 40 mm and the height of 20 mm. (Fig 2)

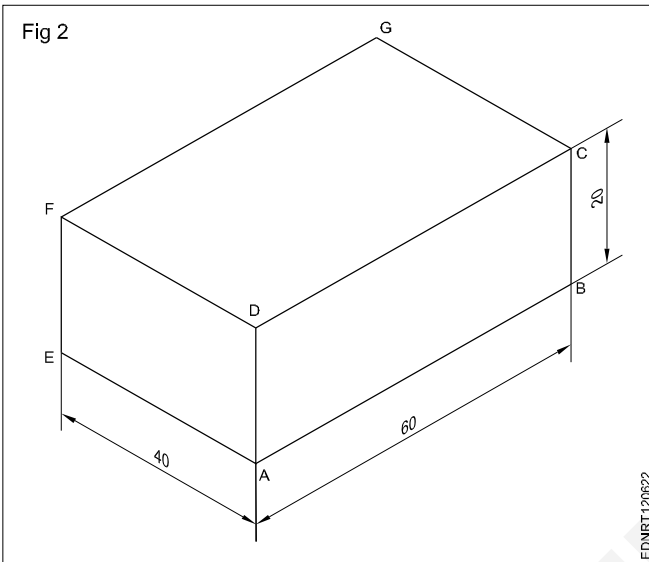

Draw the three isometric axes through the point 'A'.

- Mark $AB = 60\text{mm}$, $AE = 40\text{mm}$ and $AD = 20\text{mm}$ representing the three sides of cuboid.
- Draw two vertical lines EF and BC parallel to AD from points E and B respectively.
- Similarly, draw two more lines parallel to AB and AE to mark G 's interesting point from F and C .
- Draw lines parallel to DC and FG Draw lines parallel to DF and GC .
- Join all the points.

Cylinder (Fig 3)

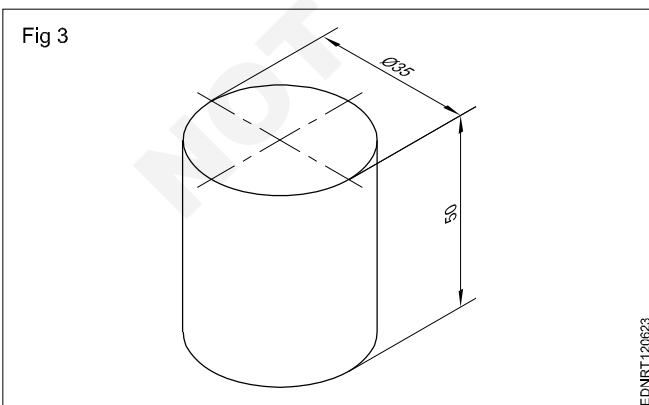

Rectangular prism (Fig 4)

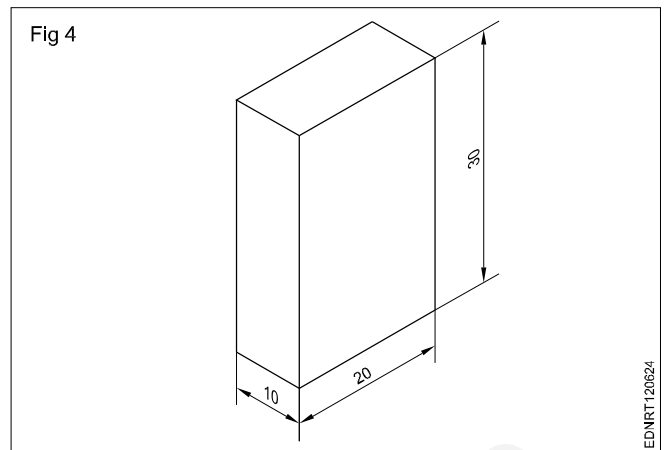

Square Prism (Fig 5)

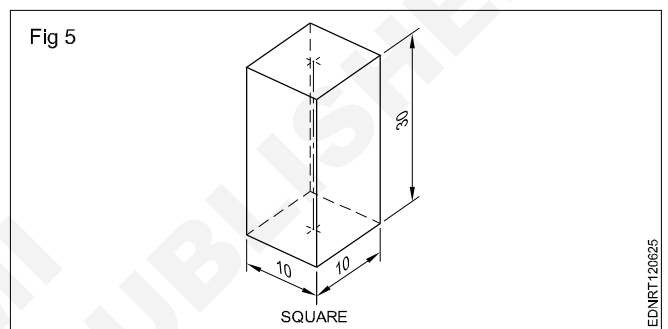

Triangular Prism (Fig 6)

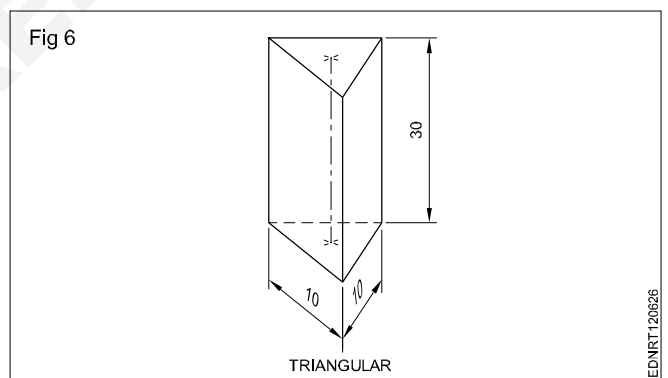

Pentagonal prism (Fig 7)

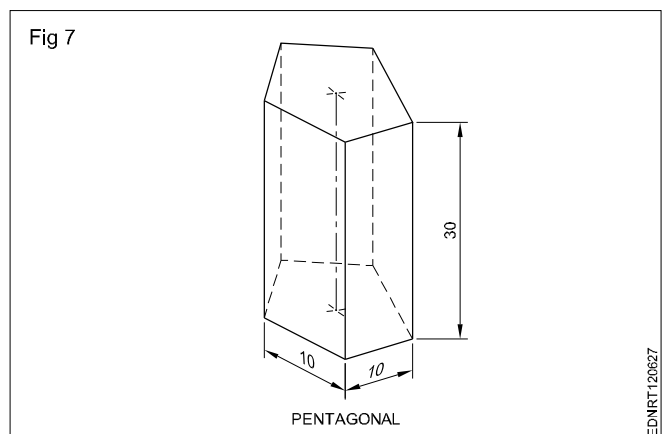

Hexagonal prism (Fig 8)

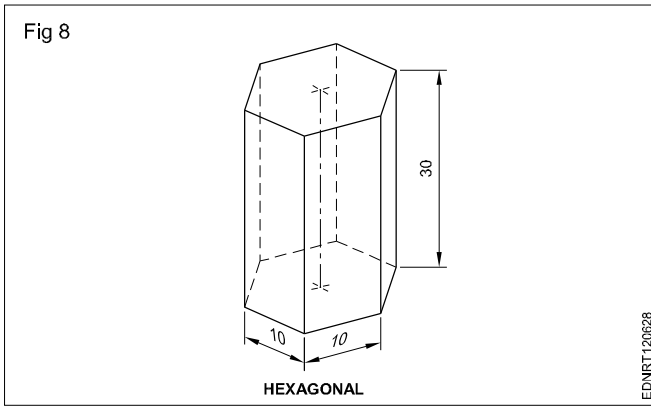

Cone: When a right-angled triangle revolves about one of its sides forming the right angle, a cone is generated. Cone forming has a circular face and a slant curved surface. (Fig 9)

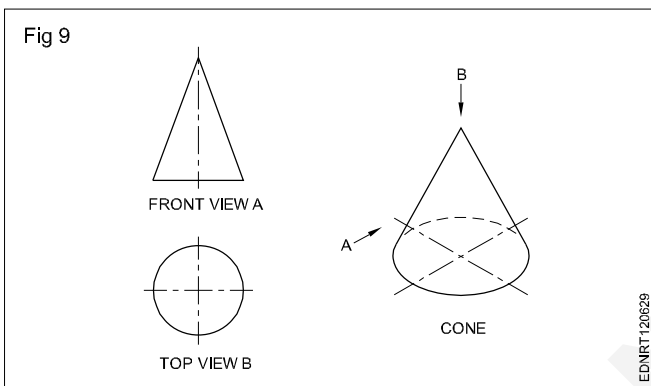

Pyramids: Pyramids are polyhedron solids having a base surface whose shape may be triangular, square or polygon and as many slant triangular faces as there are sides in the base. All the slant triangular faces join at a common point called APEX.

Similar to prisms, pyramids also are known by the shape of their base viz triangular, square, rectangular, pentagonal, hexagonal etc. The imaginary line joining the centre of the base to the apex is called the AXIS.

Fig 10 shows some pyramids and their views.

When a semi-circle revolves about its diameter a sphere is generated. A sphere has no flat surface. (Fig 11D)

Frustums: Pyramid/cone is cut parallel to the base and the top portion is removed. The remaining bottom portion is called the frustum of a pyramid/cone.

If the cutting plane is at an angle to the axis/base, the pyramids or cones are called "Truncated pyramids or cones".

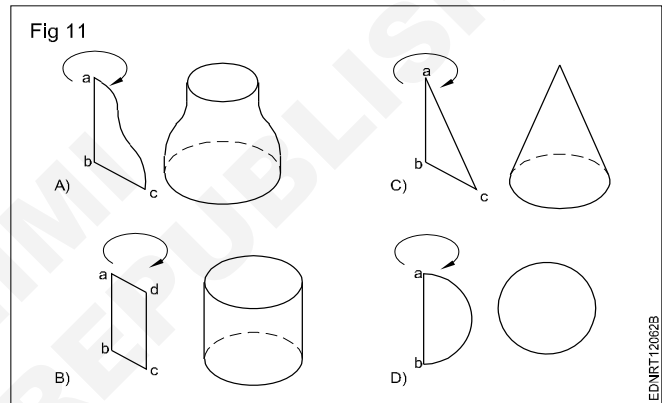
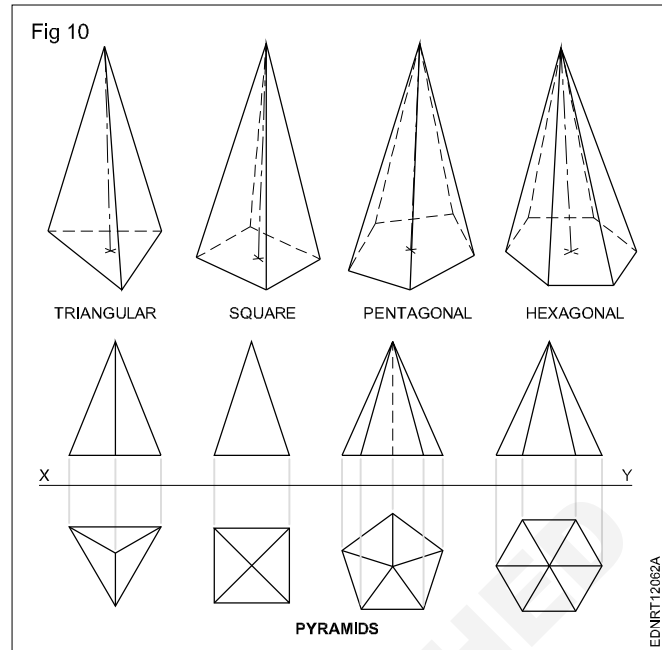
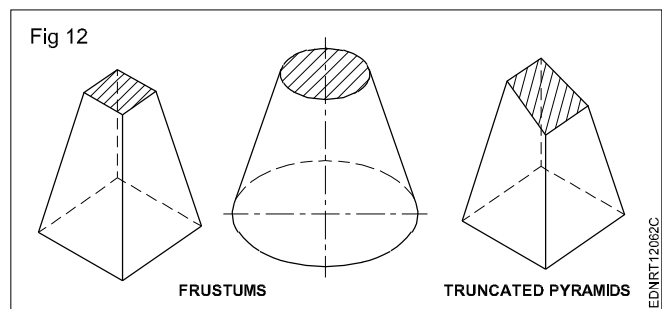

Fig 12 shows frustums and truncated pyramids.

All items we use are solids. Their shapes may confirm individual geometrical solids like prisms, cones or other combinations.



Free hand drawing of - Transferring measurement from the given object to the free hand sketches

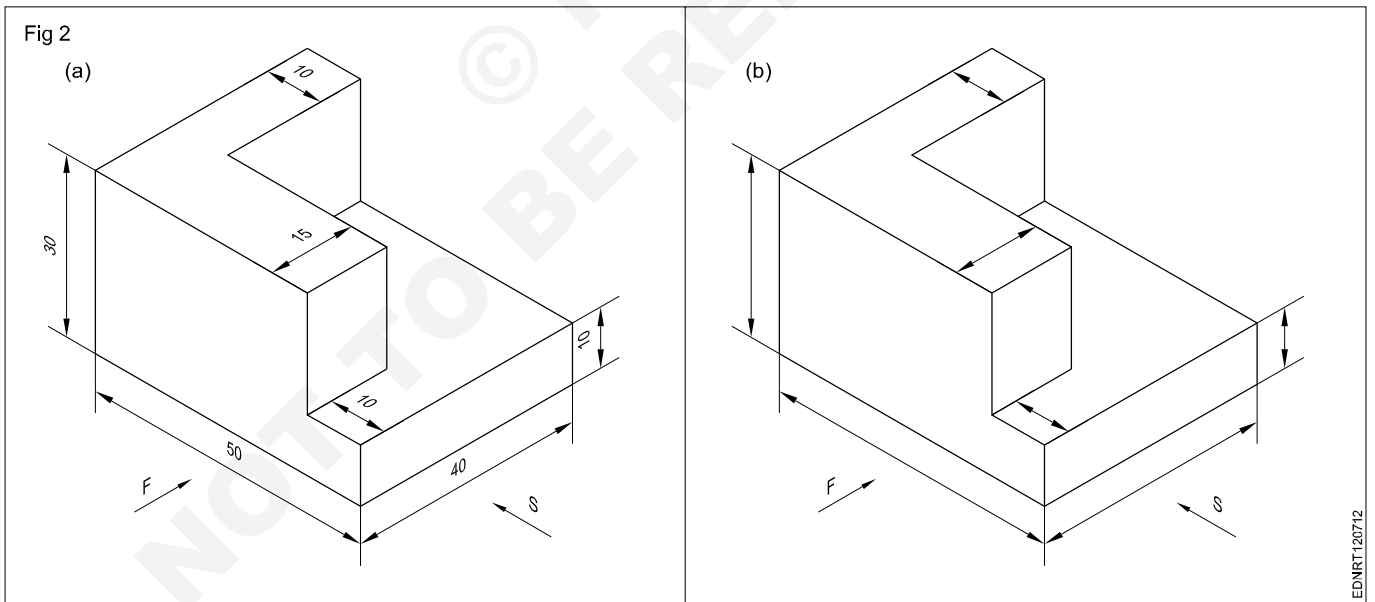
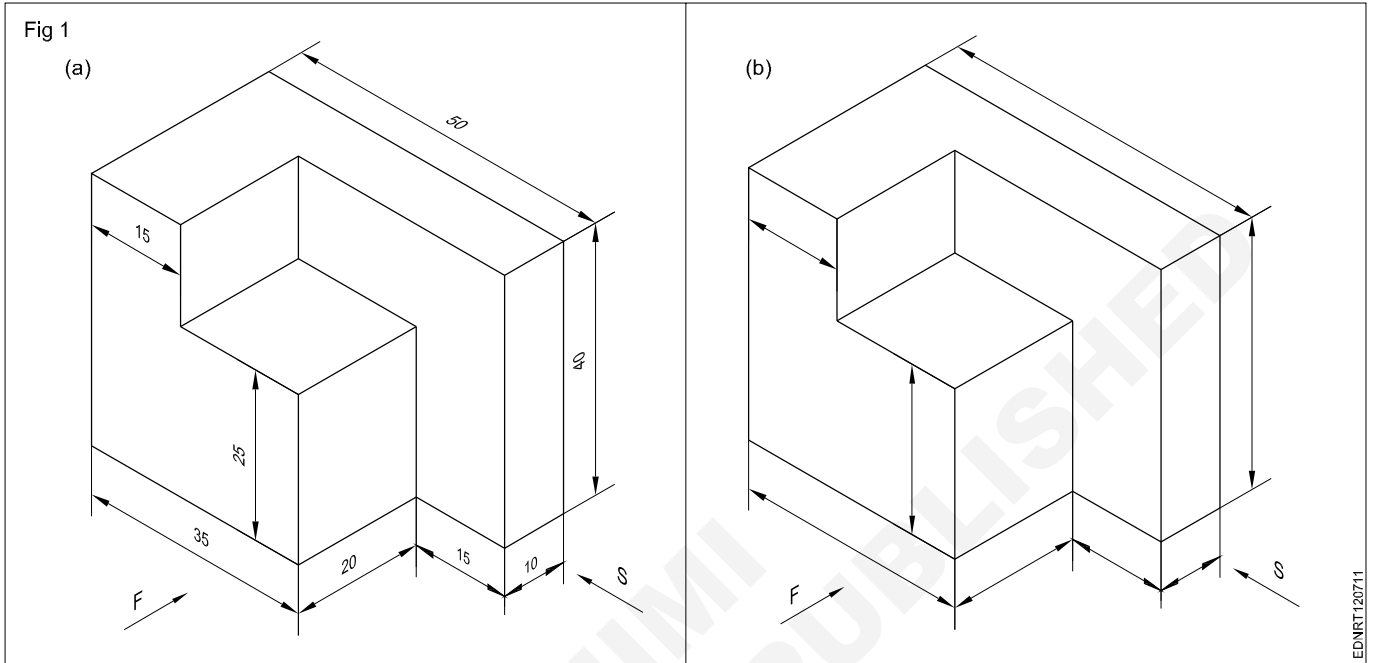
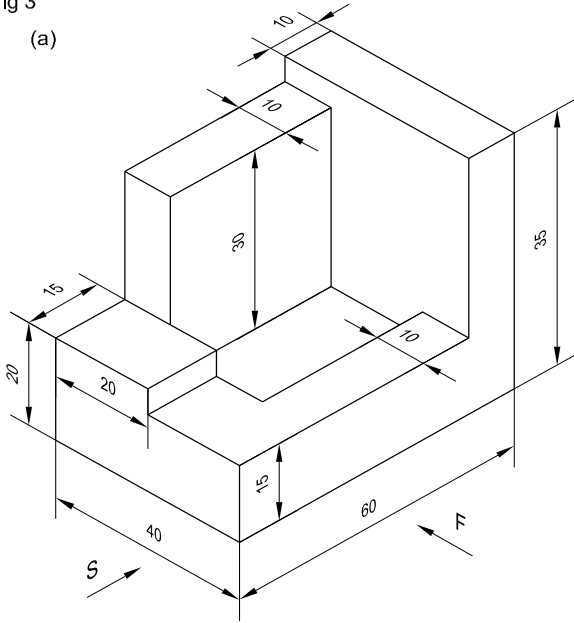
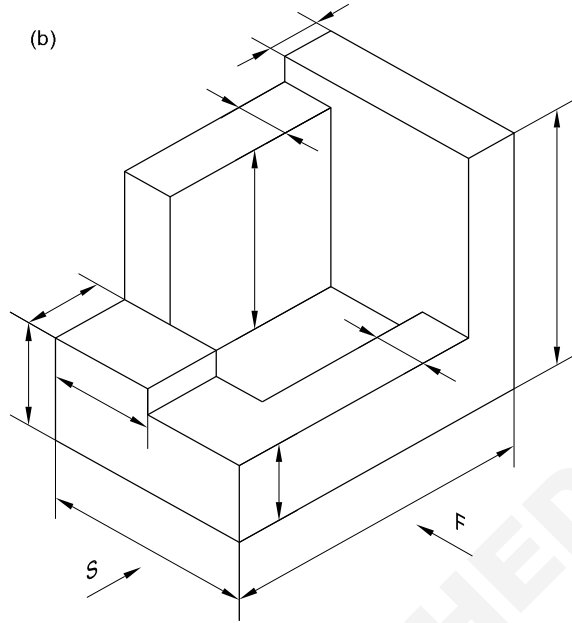

Fig 3

(a)



(b)



EDNRT120713

Fig 4

(a)

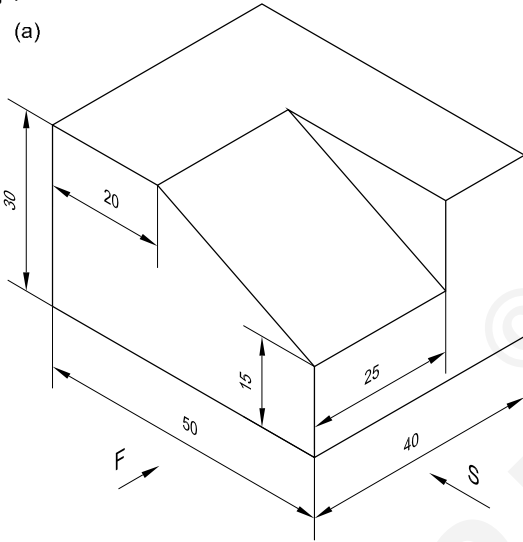

(b)

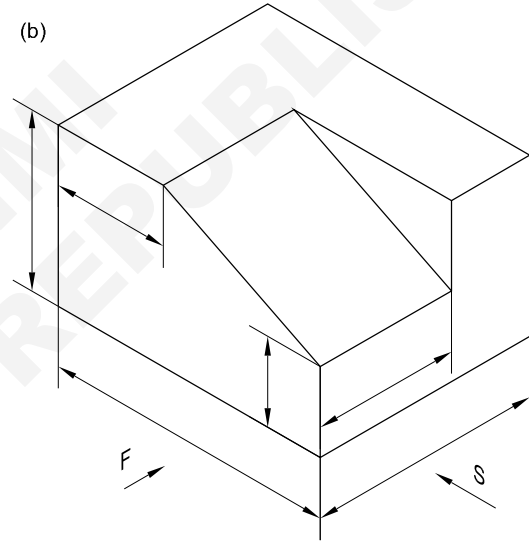

EDNRT120714

Fig 5

(a)

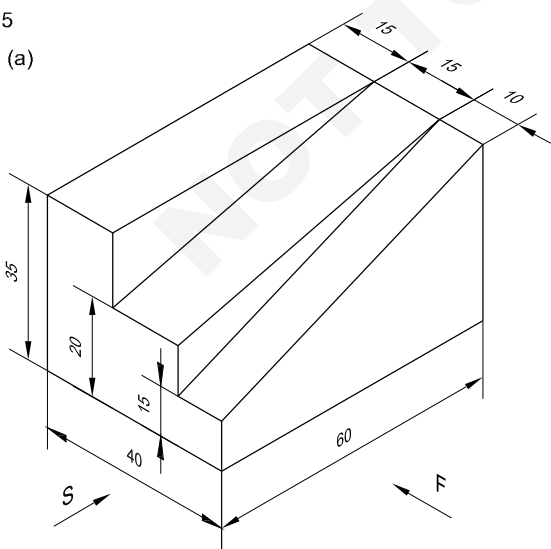

(b)

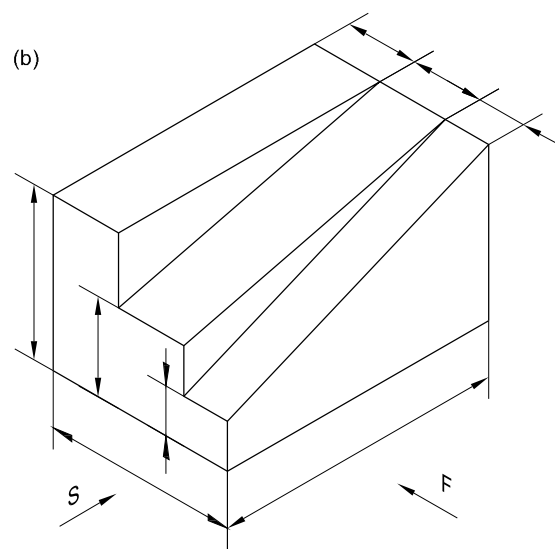

EDNRT120715

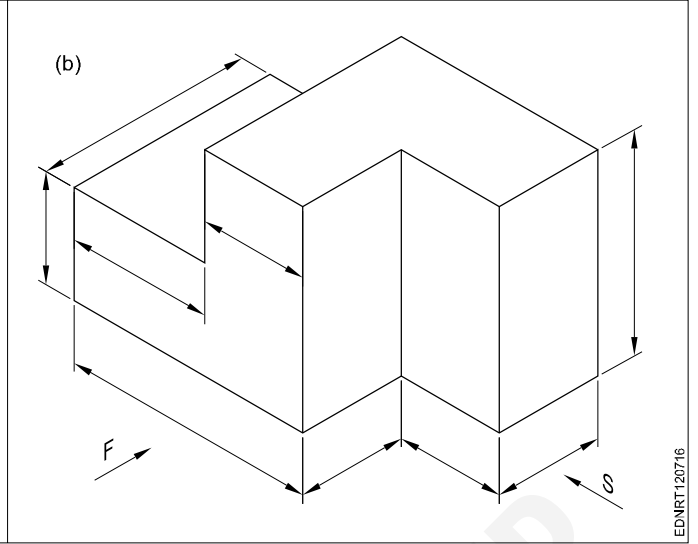
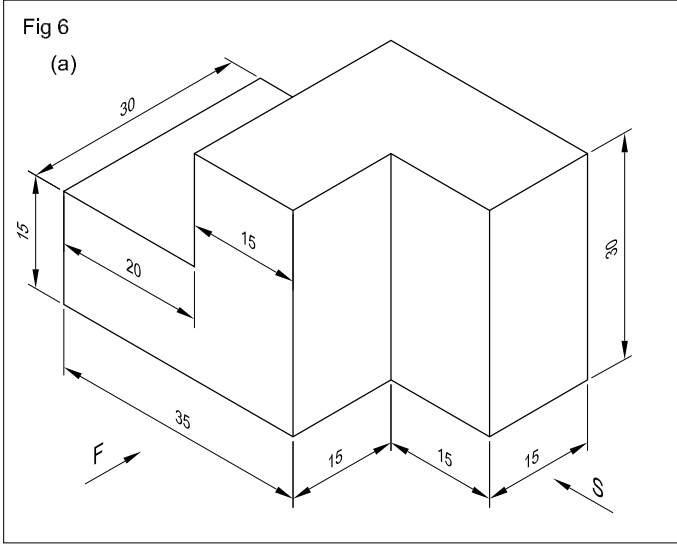

EDNRT120716

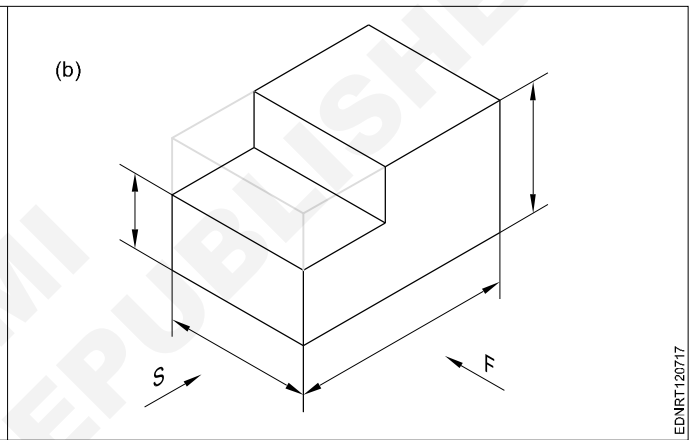
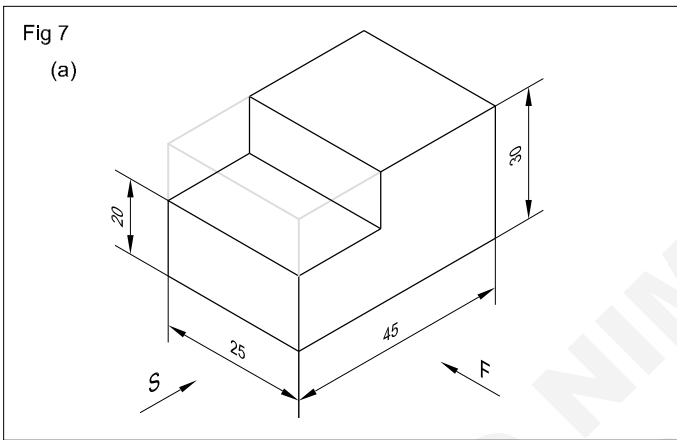

EDNRT120717

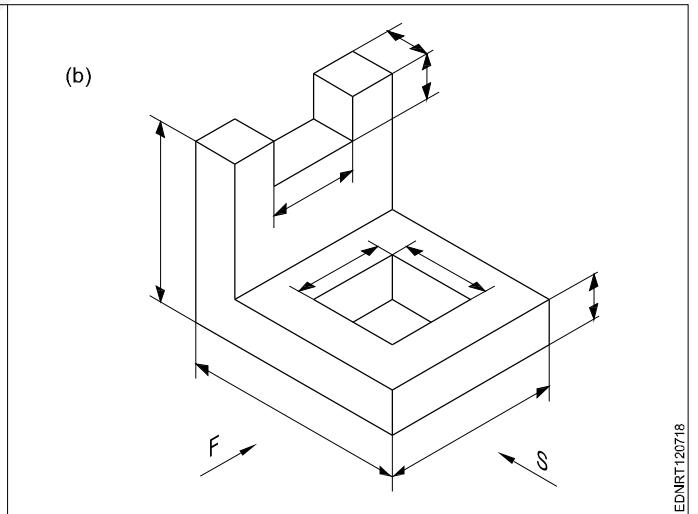
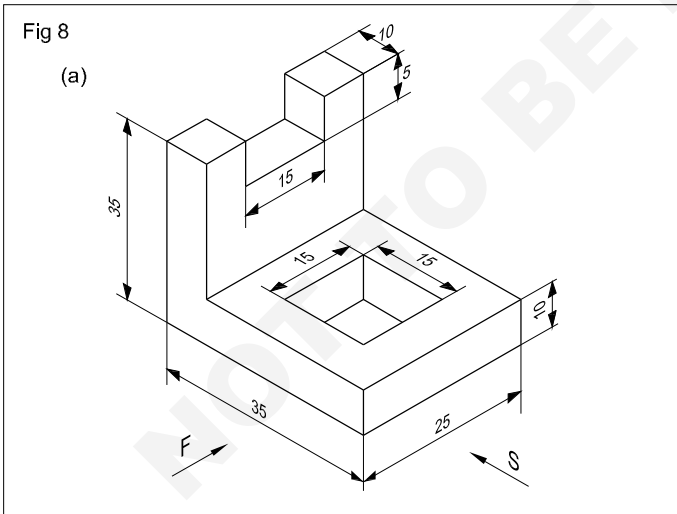

EDNRT120718

Fig 9

(a)

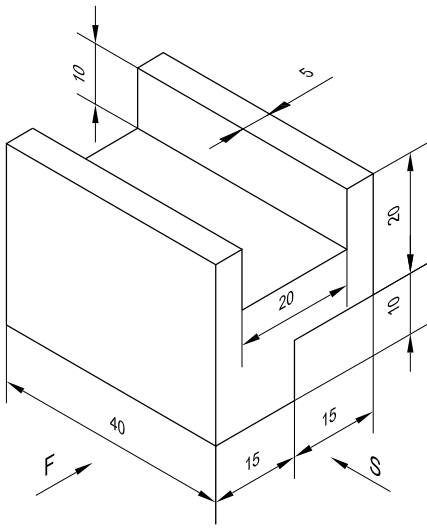

(b)

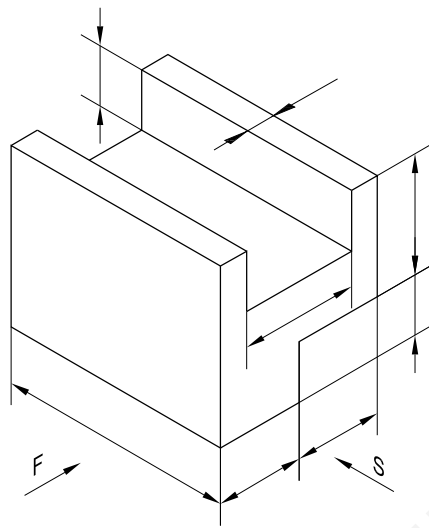

EDNRT120719

Fig 10

(a)

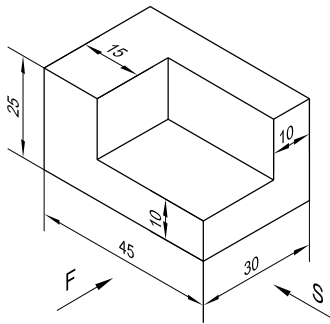

(b)

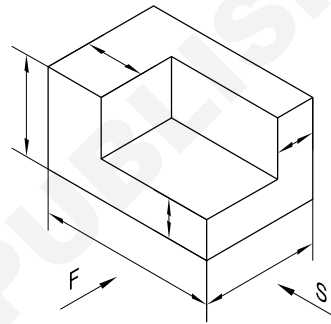

EDNRT12071A

Free hand drawing of hand tools and measuring tools

Michie-golledge, Modified gauge knife, Jebong knife (Fig 1)

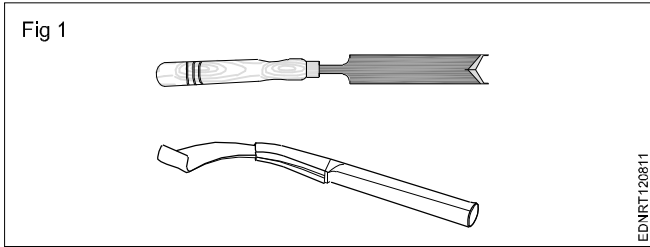

Rubber tapping knife (Fig 2)

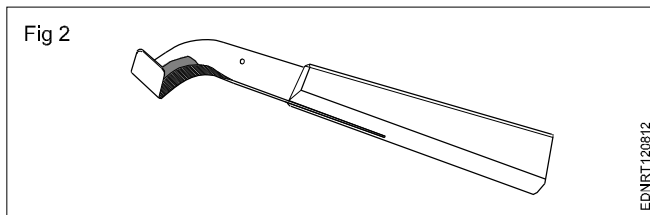

Latex cup, Latex cup hanger (Fig 3)

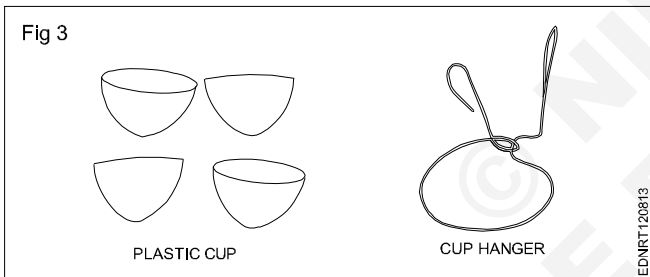

Tin spout used in latex (Fig 4)

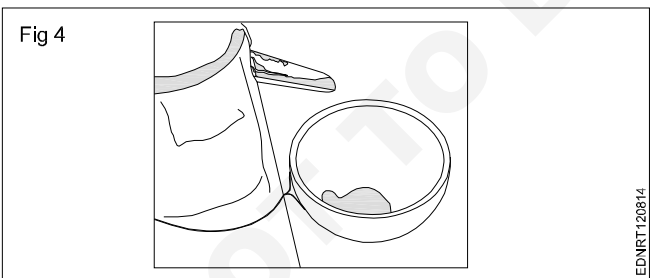

Collapsible carpenter rule (Fig 5)

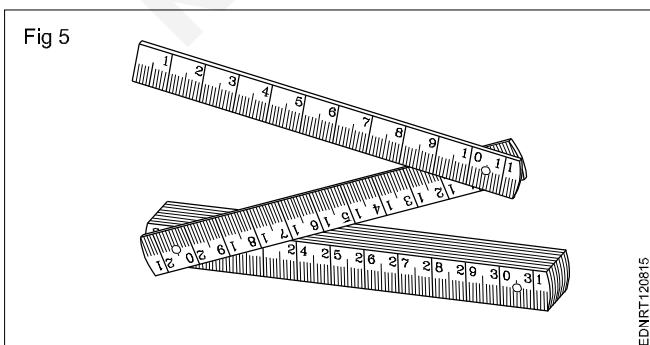

Folding rule (Fig 6)

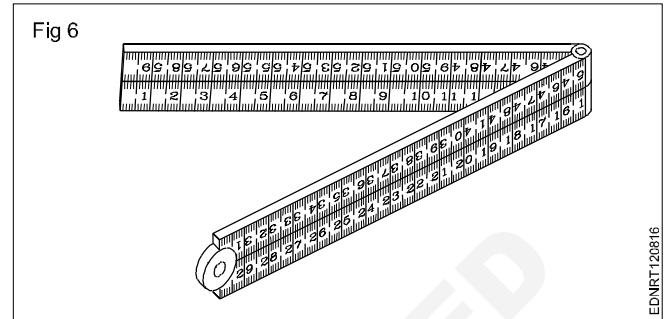

Tape Measure (Fig 7)

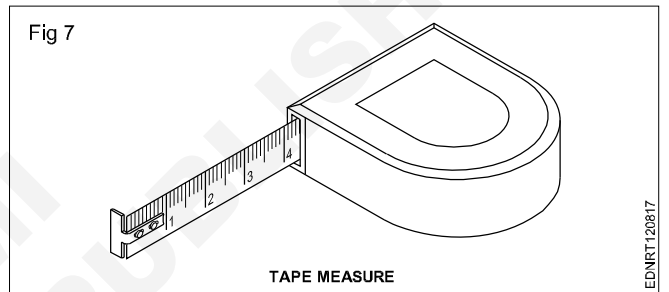

Carpenter's work bench (Fig 8)

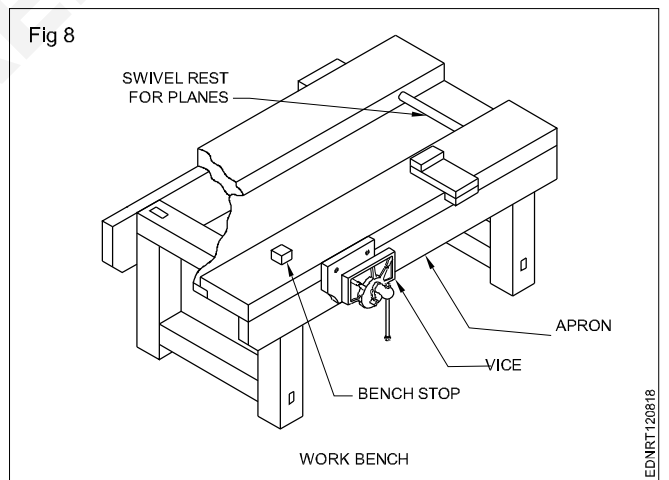

Try square (Fig 9)

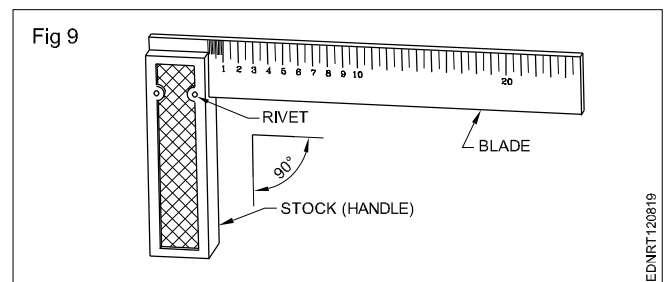

Plumb bob (Fig 10)

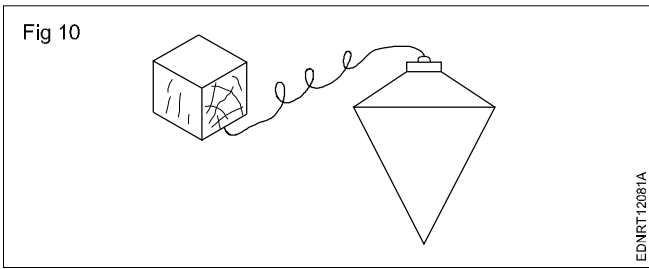

Crow bar (Fig 11)

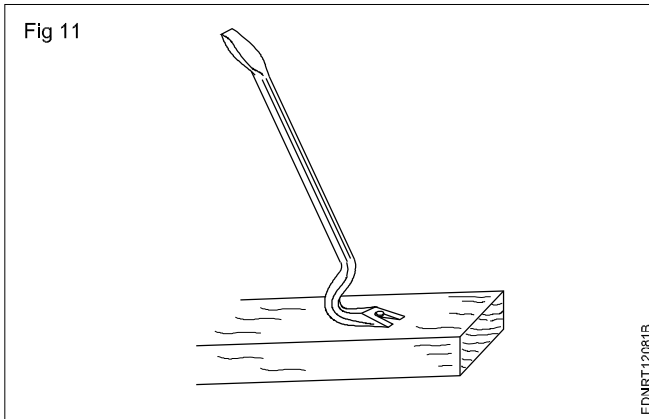

Using the trammel point (Fig 12)

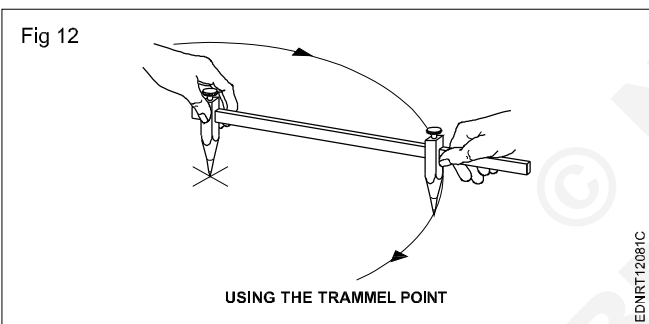

Marking knife (Fig 13)

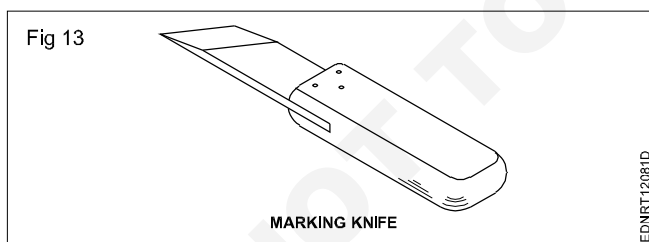

'T' - Bevels (or) bevel square (Fig 14)

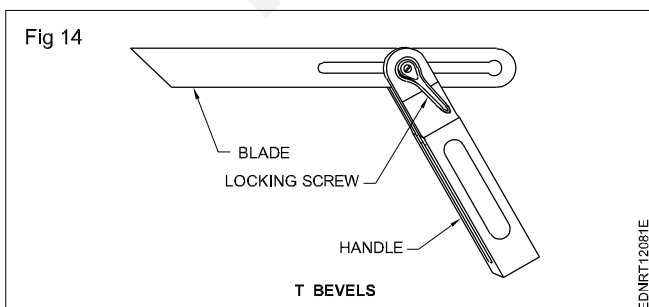

Standard wire gauge (Fig 15)

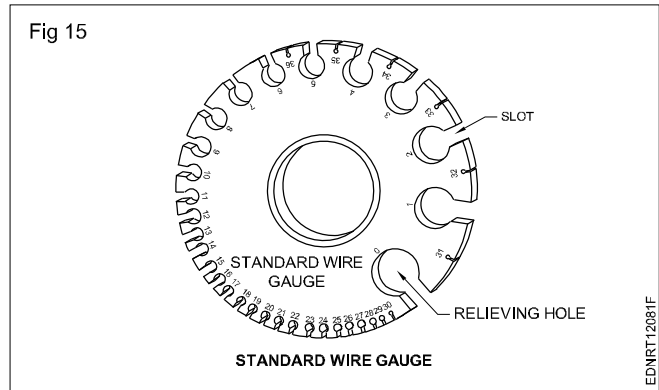

Panel gauge (Fig 16)

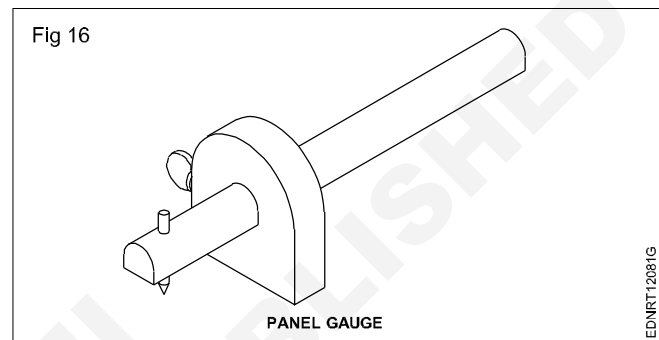

Cross cut saw (Fig 17)

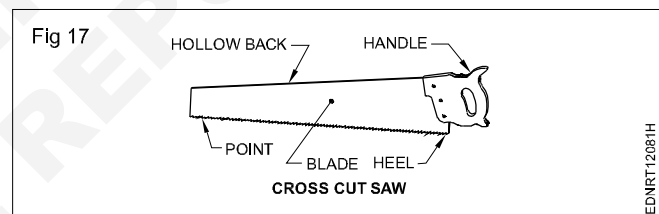

Coping saw (Fig 18)

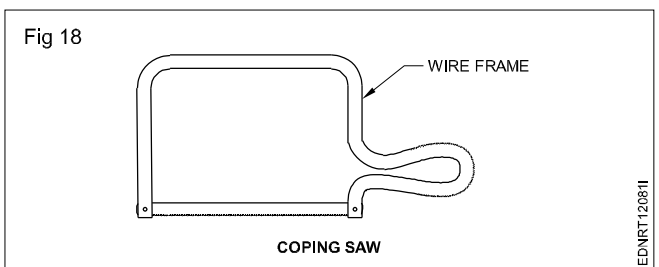

Fret saw (Fig 19)

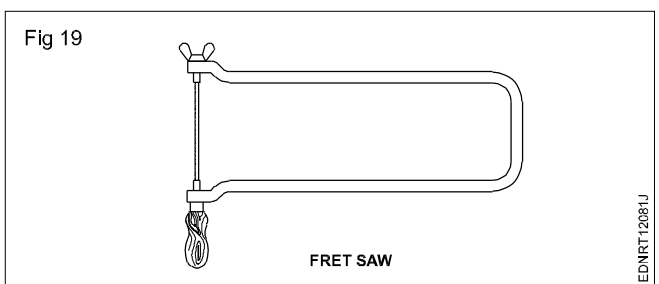

Compass saw (Fig 20)

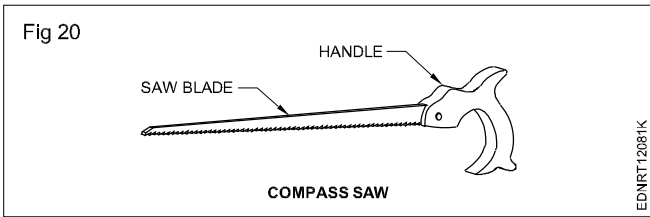

Bow saw (Fig 21)

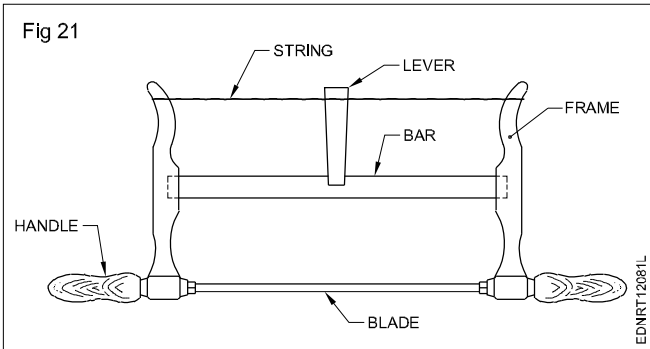

Key hole saw (Fig 22)

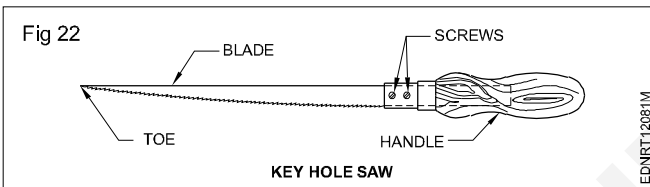

Butt gauge (Fig 23)

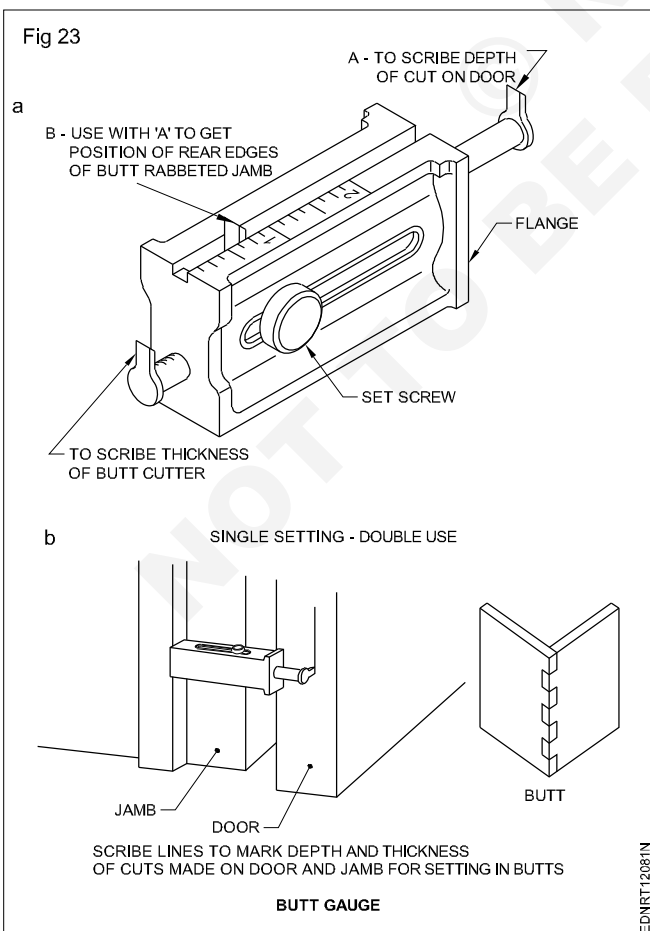

Pairs of pincers (Fig 24)

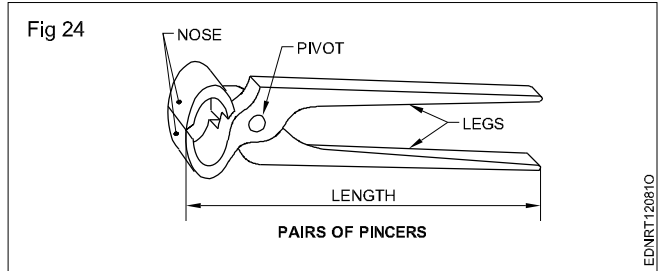

Marking gauge (Fig 25)

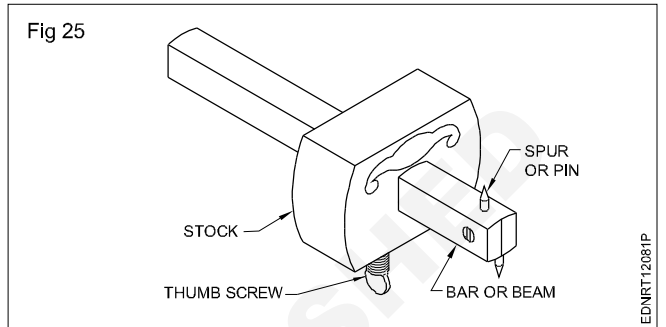

Marking knife (or scriber knife) (Fig 26)

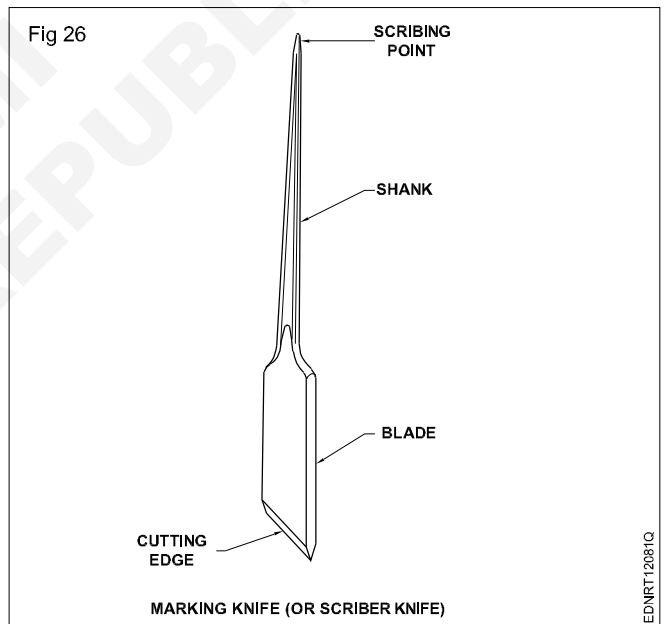

Steel scriber (Fig 27)

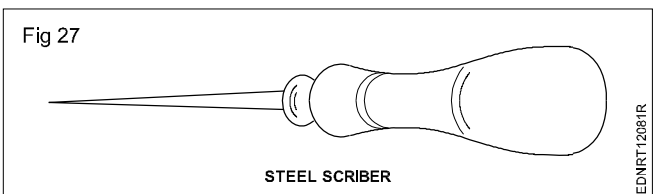

Trammel points (Fig 28)

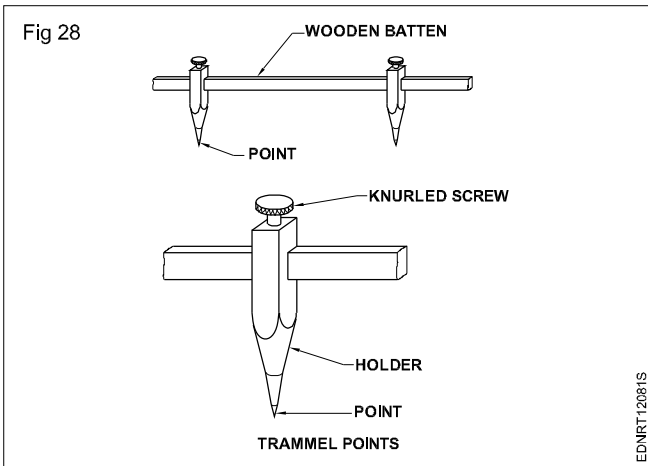

'G' clamp (Fig 32)

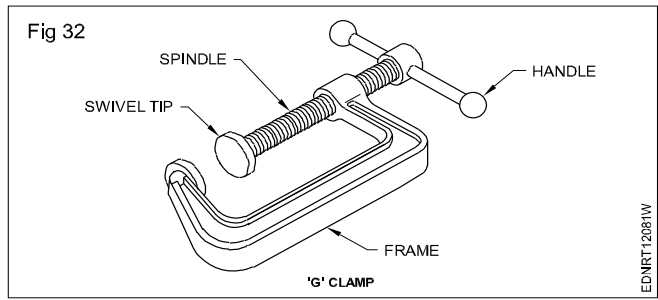

Wing compasses (Fig 29)

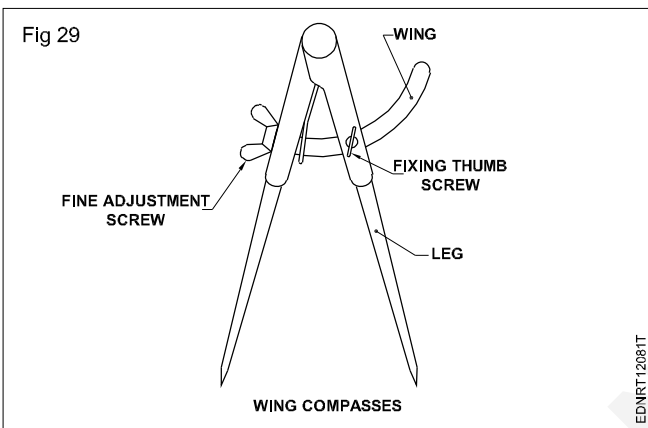

Bench hold fast (Fig 33)

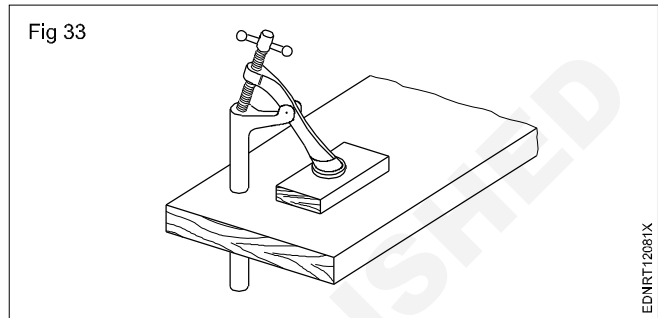

The Cleat (Fig 34)

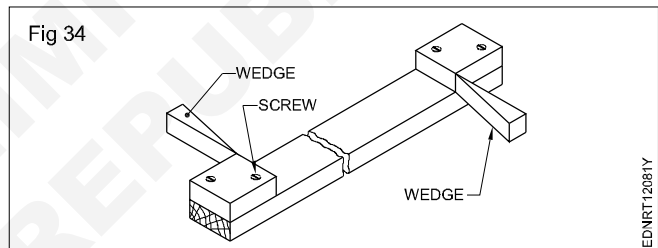

Hand screw (Fig 30)

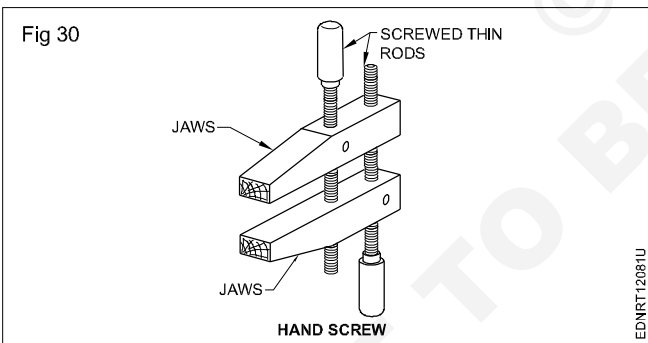

Rip saw (Fig 35)

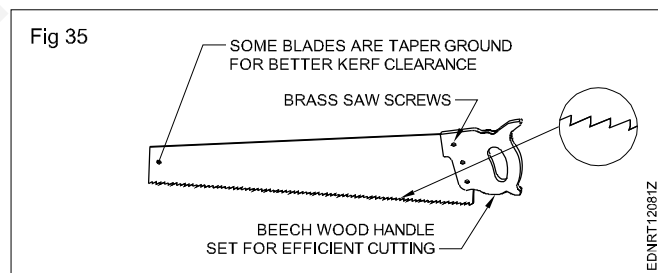

Bar clamp (Fig 31)

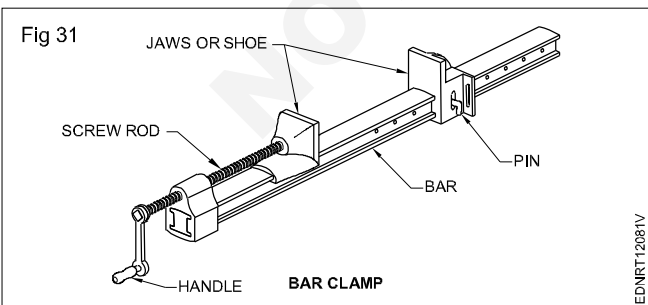

Tenon saw (Fig 36)

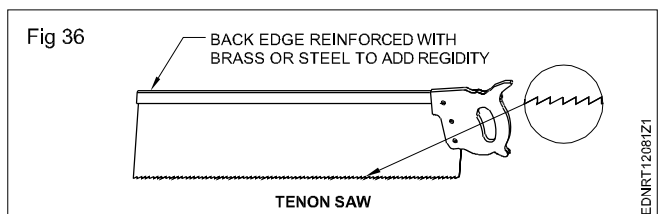

Country drill (Fig 37)

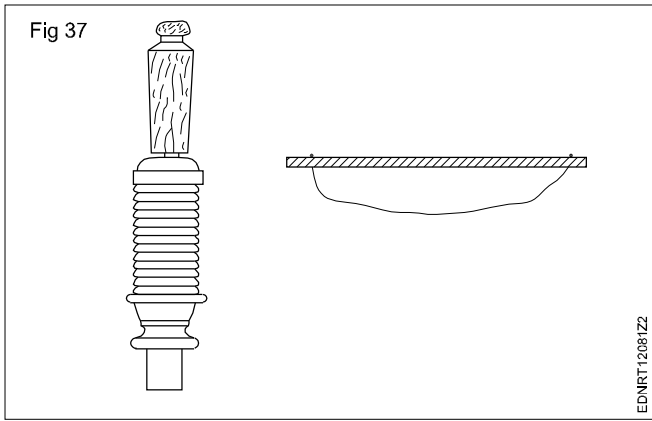

Irwin pattern twist bit (Fig 40)

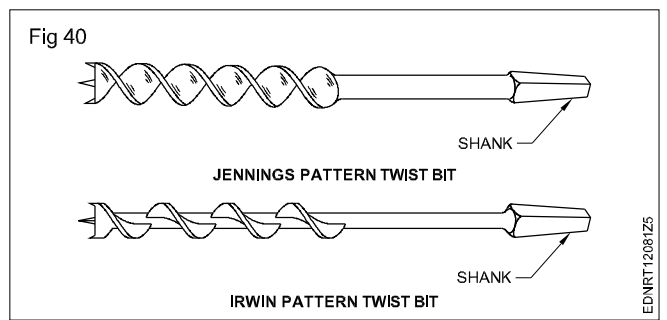

Hand drill machine (Fig 38)

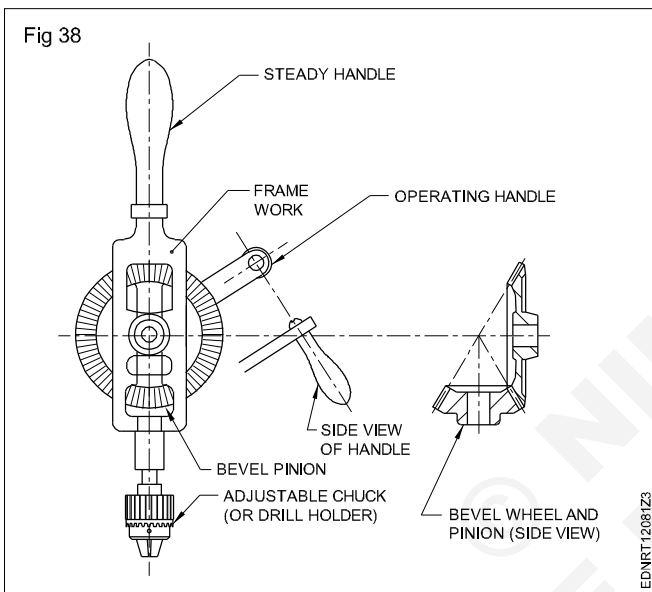

Centre bit (Fig 41)

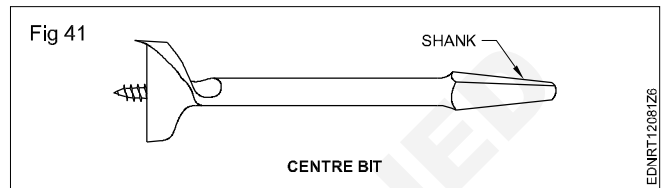

Wooden jack plane (Fig 42)

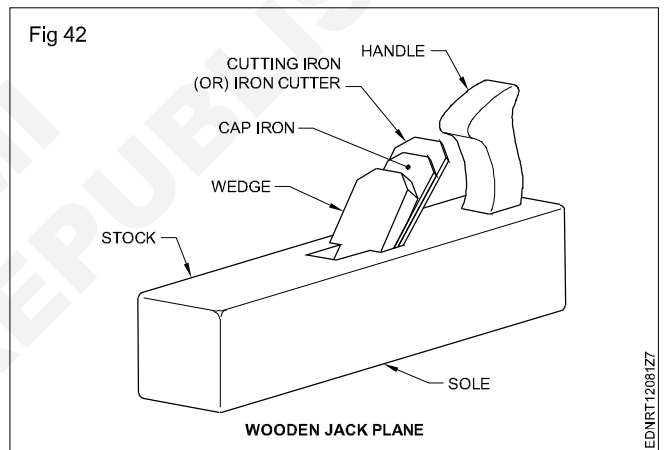

Plain brace (Fig 39)

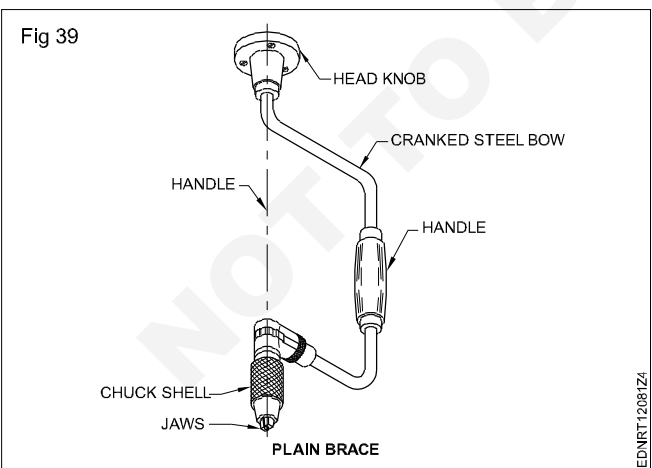

Smoothing plane (Fig 43)

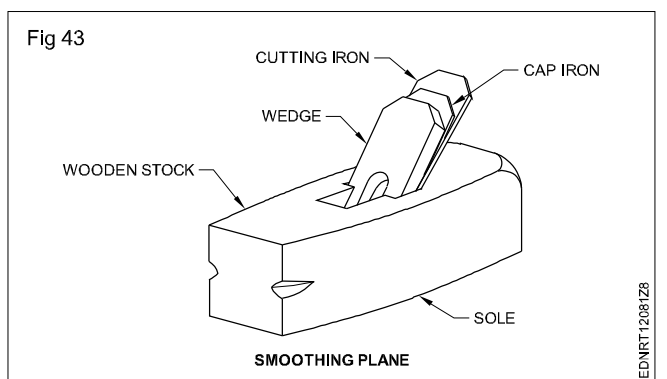

Bench firmer chisel (Fig 44)

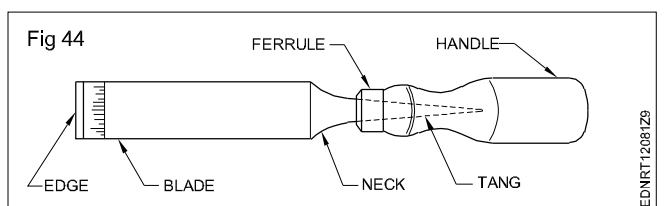

Bevel edge firmer chisel (Fig 45)

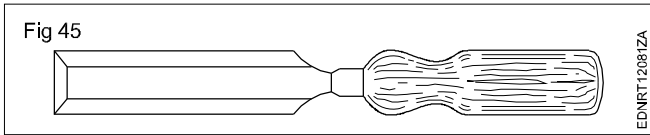

Registered firmer chisel (Fig 46)

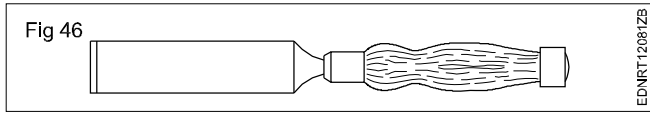

Paring chisel (Fig 47)

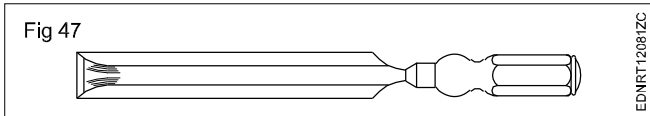

Socket firmer or socket mortise (Fig 48)

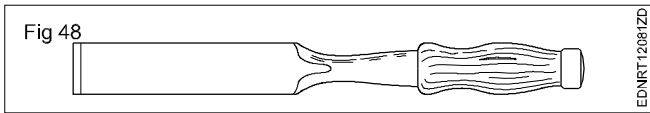

Inside bevelled gouge (Fig 49)

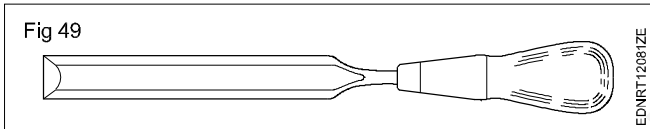

Outside bevelled gouge (Fig 50)

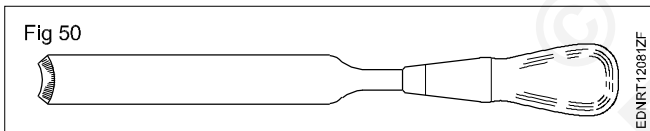

Parts of hammer head (Fig 51)

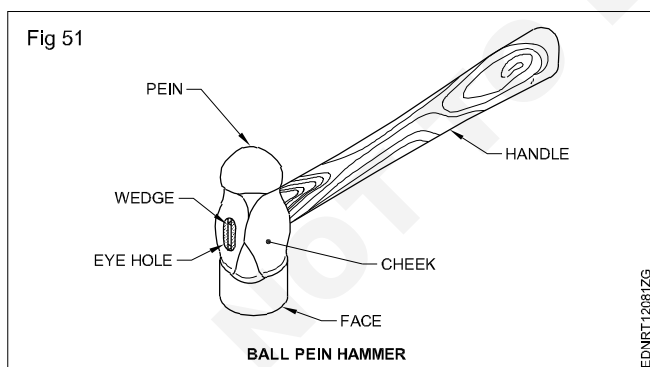

Types of hammer (Fig 52)

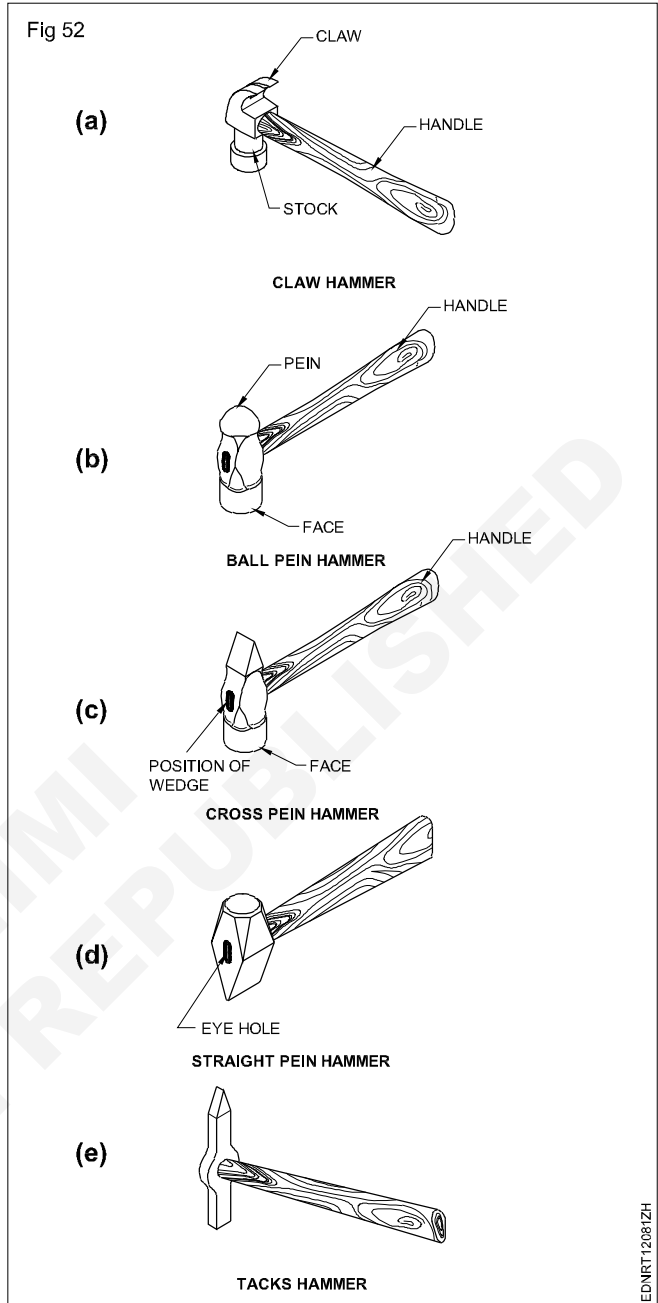

Mallet with removable head (Fig 53)

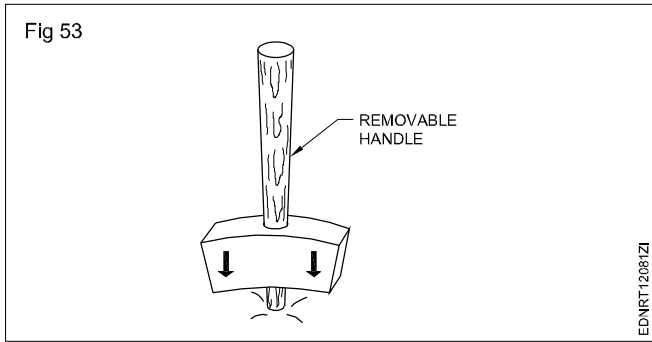

Round head & Square head mallets (Fig 54)

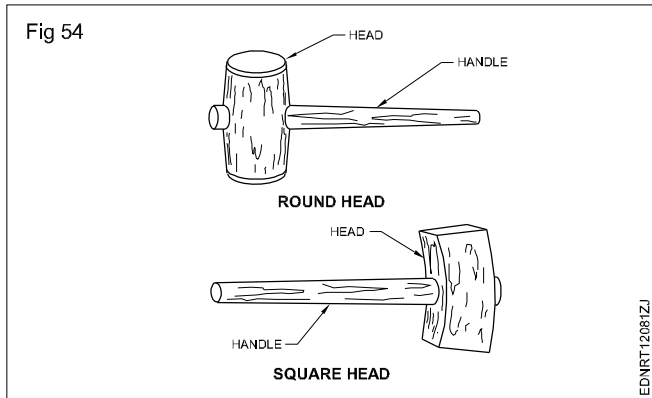

Wood file (Fig 55)

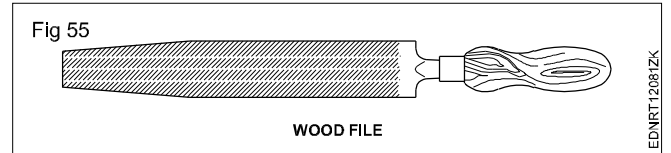

Rasp file (Fig 56)

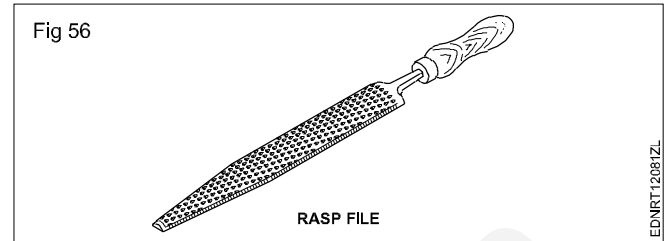

© NIMI
NOT TO BE REPUBLISHED

Drawing of geometrical figures - Angle & triangle

Angles: Angle is the inclination between two straight lines meeting at a point or meeting when extended. AB and BC are two straight lines meeting at B. The inclination between them is called an angle. The angle is expressed in degrees or radians.

Concept of a degree: When the circumference of a circle is divided into 360 equal parts and radial lines are drawn through these points, the inclination between the two adjacent radial lines is defined as one degree. Thus a circle is said to contain 360°. (Fig 1)

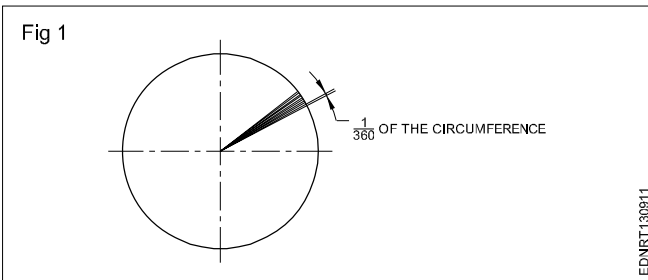

Acute angle: An angle that is less than 90° is called an acute angle. (Fig 2)

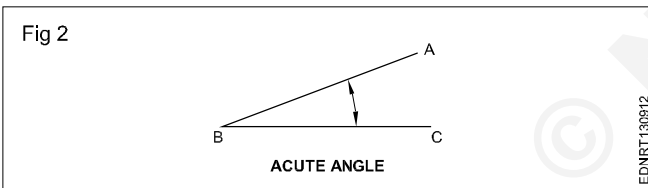

Right angle: The angle between a reference line and a perpendicular line is called a right angle. (Fig 3)

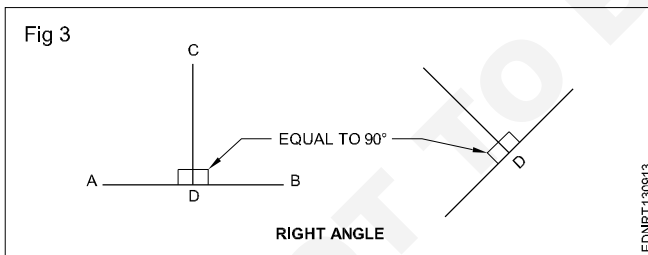

Obtuse angle: This refers to an angle between 90° and 180°. (Fig 4)

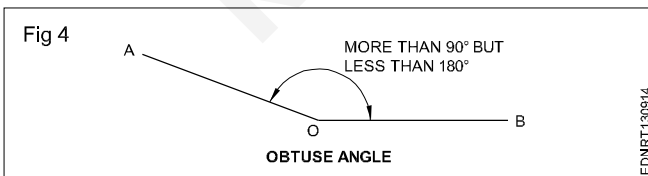

Straight angle: This refers to an angle of 180°. This is also called the angle of a straight line. (Fig 5)

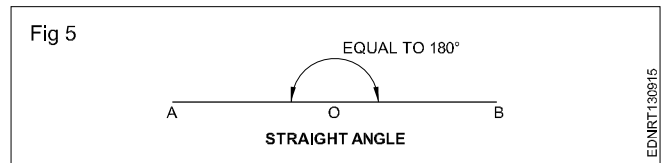

Reflex angle: It is the angle that is more than 180°, but less than 360°. (Fig 6)

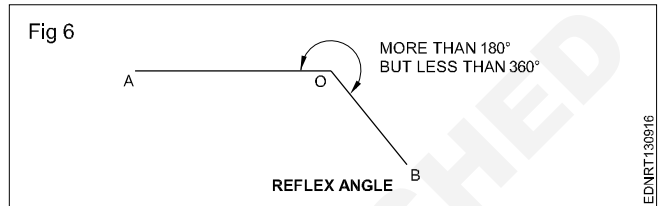

Adjacent angles: These are the angles lying on either side of a line. (Fig 7)

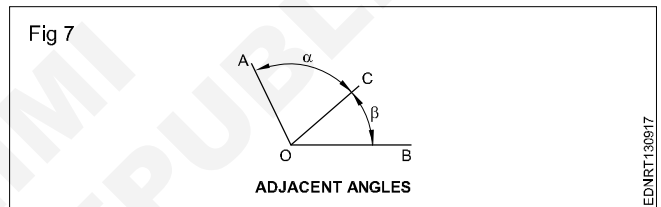

Complementary angles: When the sum of the two angles is equal to 90°, angle POQ + angle QOR = 90° angle POQ and angle QOR are complementary angles to each other. (Fig 8)

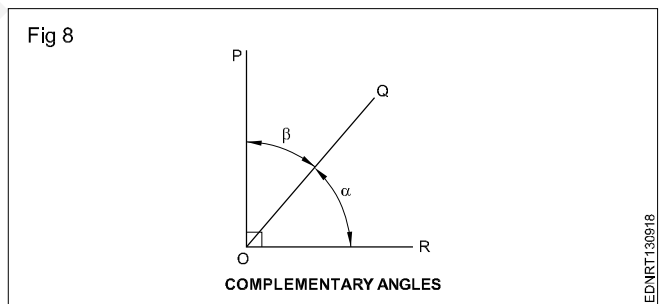

Supplementary angle: When the sum of the two adjacent angles is equal to 180°, for example, angle SOT + angle TOY = 180°, angle SOT and angle TOY are supplementary angles to each other. (Fig 9)

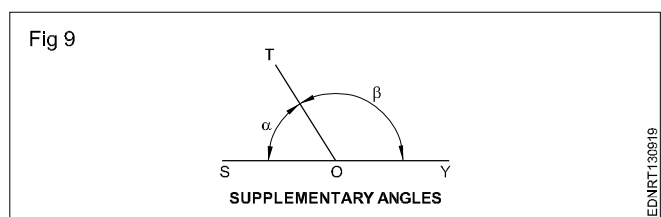

Triangle - different types

Triangle is a closed plane figure having three sides and three angles. The sum of the three angles always equals to 180° .

To define a triangle, we need to have a minimum of three measurements as follows:

- 3 sides or
- 2 sides and one angle or
- 2 angles and one side

Types of triangles

1 Equilateral triangle is a triangle having all the three sides equal. Also all the three angles are equal (60°). (Fig 1)

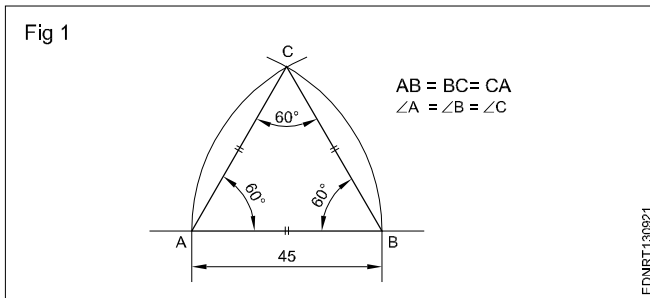

2 Isosceles triangle has two of its sides equal. The angles opposite the two equal sides are also equal. (Fig 2)

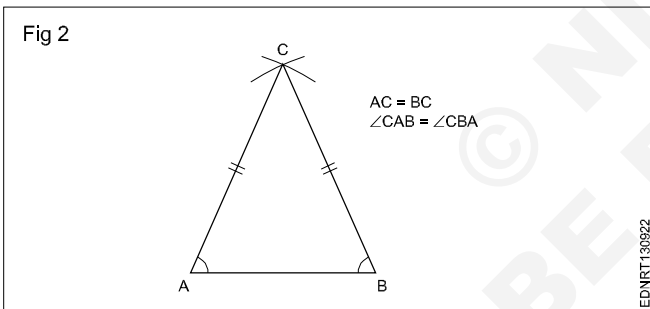

3 Scalene triangle has all three sides unequal in length. All three angles are also unequal. (Fig 3)

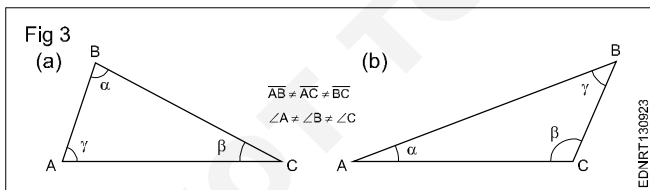

4 A right-angled triangle is one in which one of the angles is equal to 90° (Right angle). The side opposite the right angle is called the hypotenuse. (Fig 4)

5 An Acute angled triangle is one in which all the three angles are less than 90° . (Fig 5)

6 Obtuse angled triangle has one of the angles more than 90° . (Fig 6)

The sum of the three angles in any triangle is equal to 180° .

The sum of any two sides is more than the third side.

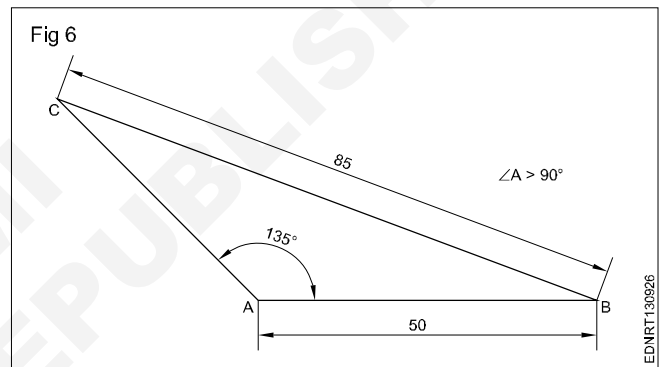
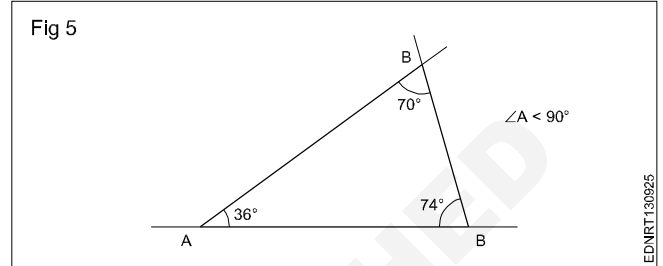
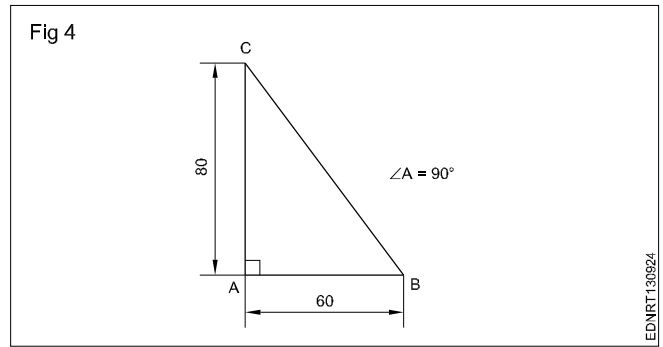

Procedure to draw the triangle

- 1 Equilateral triangle (Fig 1) $AB = BC = CA = 35$ mm.**
 - Draw a line and mark AB 35 mm side of the triangle.
 - Draw radius from centre A and B, arcs cutting mark at C (Fig 1).
 - Join CA and CB.
 - ABC is a required triangle.

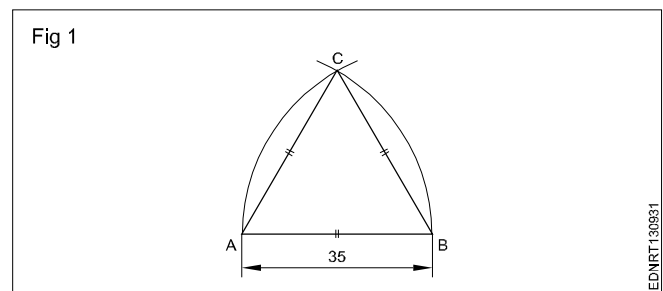

2 Isosceles triangle : $AB = AC = 60$ mm & $\angle BAC = 40^\circ$.

- Draw the side AB equal to 60 mm. 'A' as the centre, draw an arc of radius AB.
- Draw a line AC at 40° to AB.
- Join BC to form the triangle ABC. (Fig 2)

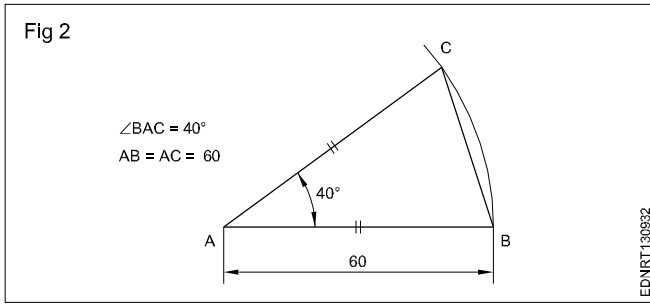

Exercise

- 1 Scalene triangle: $AB = 30$ mm, $AC = 55$ mm & $BC = 35$ mm. (Fig 1)

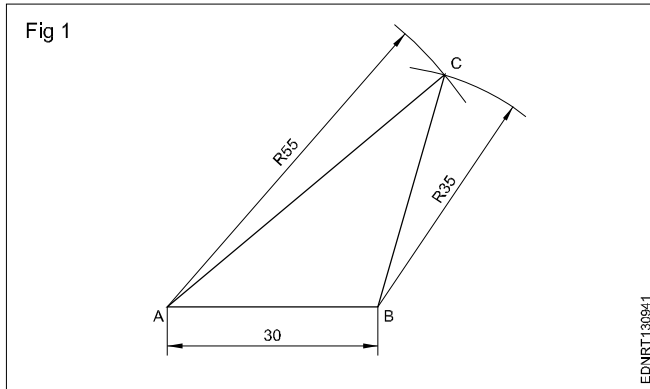

- 2 Scalene triangle: $AB = 70$ mm. (Fig 2)

$\angle ABC = 40^\circ$ & $\angle BAC = 110^\circ$

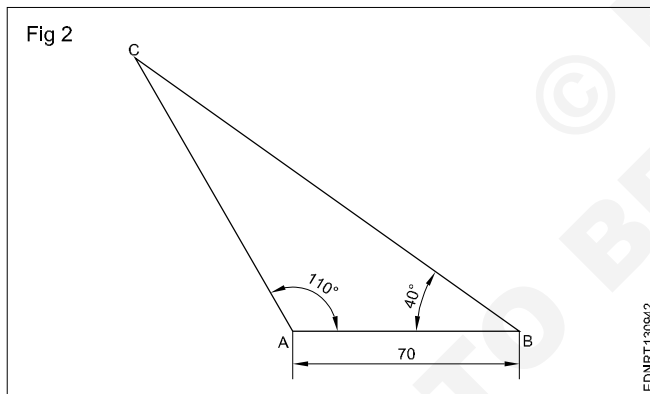

- 3 Right angled triangle: $AB = 60$ mm, $BC = 45$ mm. (Fig 3)

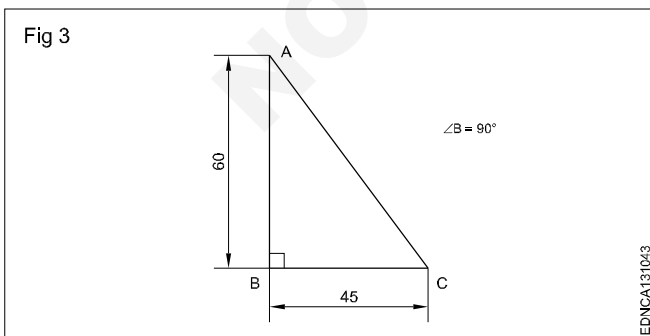

- 4 Draw a triangle when one side and 2 angles being given in Fig 4.

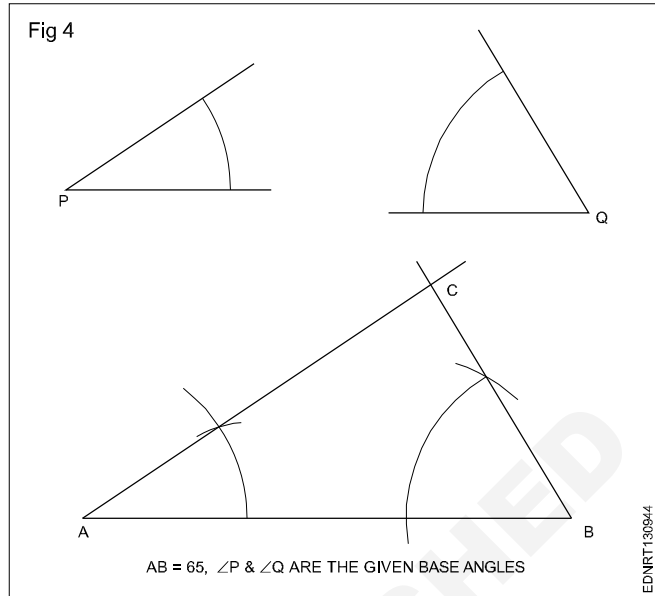

- 5 Draw a right angled triangle when the base and hypotenuse being given in Fig 5.

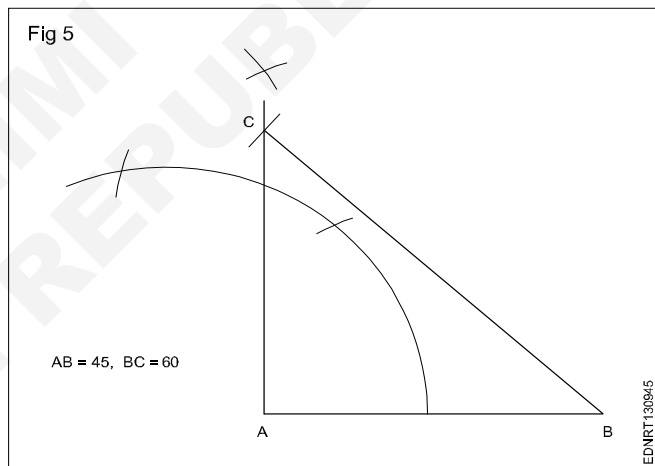

- 6 Draw a triangle with the altitude and two sides being given in Fig 6.

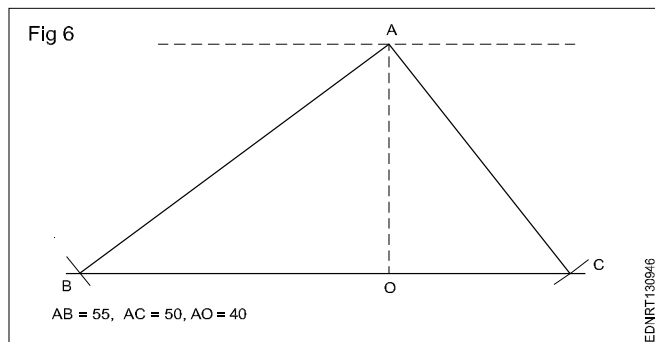

Drawing of geometrical figures - Circle

Circle: Circle is a plane figure bounded by a curve, formed by the locus of a point which moves so that it is always at a fixed distance from a stationary point the "Centre".

Radius: The distance from the centre to any point on the circle is called the "Radius".

Diameter: The length of a straight line between two points on the curve, passing through the centre is called the "Diameter". (D: Dia or d) It is twice the radius.

Circumference: It is the linear length of the entire curve, equal to πD .

Arc: A part of the circle between any two points on the circumference or periphery is called an 'Arc'.

Chord: A straight line joining the ends of an arc is called the chord. (Longest chord of the circle is the diameter)

Segment: A part of the circle or area bound by the arc and chord is the segment of the circle.

Sector: It is the part of a circle bounded by two radii (plural of radius) meeting at an angle and an arc.

Quadrant: Part of a circle with radii making 90° with each other is a quadrant (one-fourth of the circle).

Half of the circle is called a semi-circle.

Tangent: The tangent of a circle is a straight line just touching the circle at a point. It does not cut or pass through the circle when extended.

Fig 1 shows all the above elements.

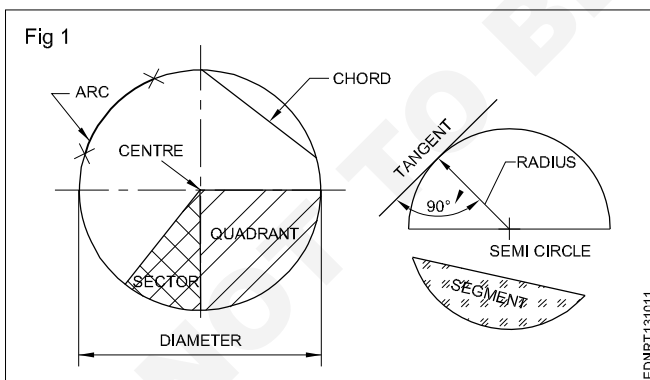

Concentric circles: When two or more circles (drawn) have a common centre, they are called concentric circles. Ball-bearing is the best example of concentric circles. (Fig 2)

Eccentric circles: Circles within a circle but with different centres are called eccentric circles. (Fig 3)

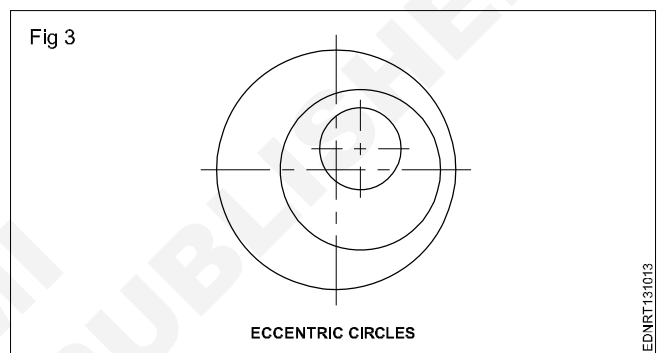
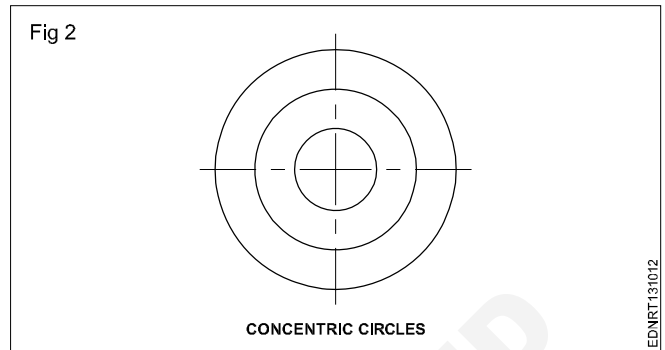

Circle and Arcs

Exercise

- 1 Draw a tangent to a given circle of ϕ 50 mm at any point 'P' on it. (Fig 1)

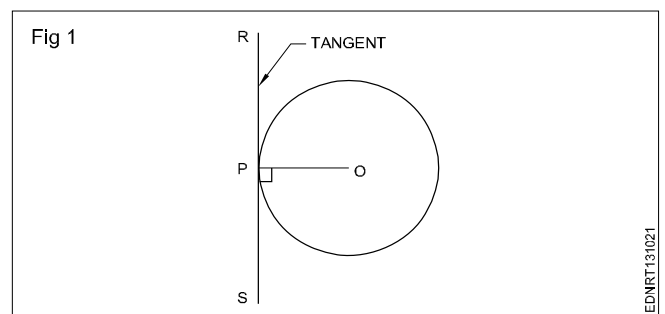

- 2 Draw a loop of 3 circles pattern. (Fig 2)

Draw any line MN and mark points A, B and C. So that AB = 20 mm and BC = 25 mm.

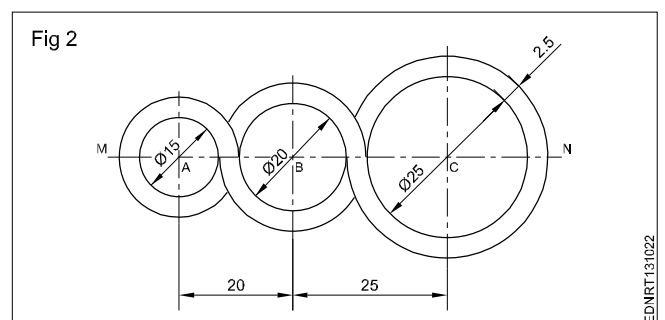

3 3 Draw three circles tangential to each other if centres A, B & C are given. (Fig 3)

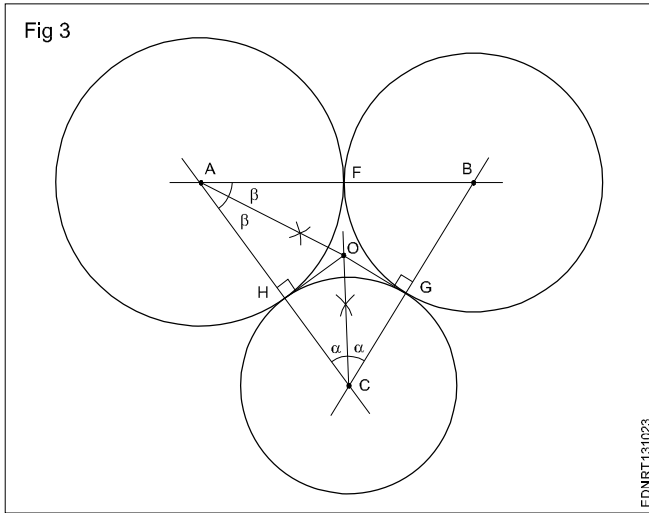

4 Draw external tangents to circles of dia 40 and 30 and centre distance 60 mm. (Fig 4)

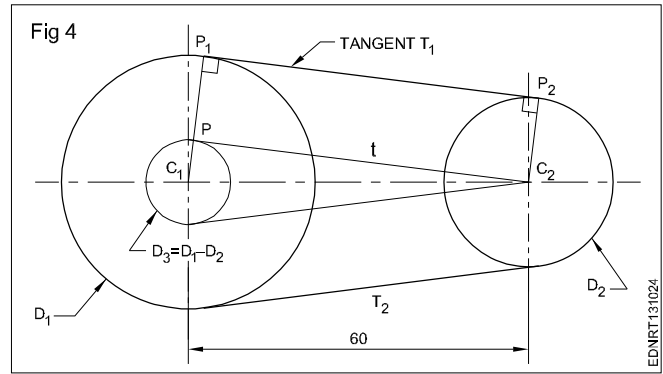

5 Draw internal tangents to circles of the same diameter 40 each and a centre distance of 60 mm. (Fig 5)

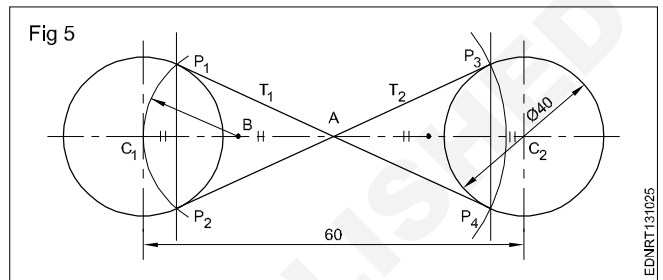

Drawing of geometrical figures - Square, rectangle and parallelogram

A quadrilateral is a plane figure bounded by four sides and four angles. The sum of the four angles in a quadrilateral is (interior angles) equal to 360° . The side joining opposite corners is called diagonal. To construct a quadrilateral out of four sides, four angles and two diagonals a minimum of five dimensions are required of which two must be sides. Quadrilaterals are also referred as Trapezium. (Fig 1)

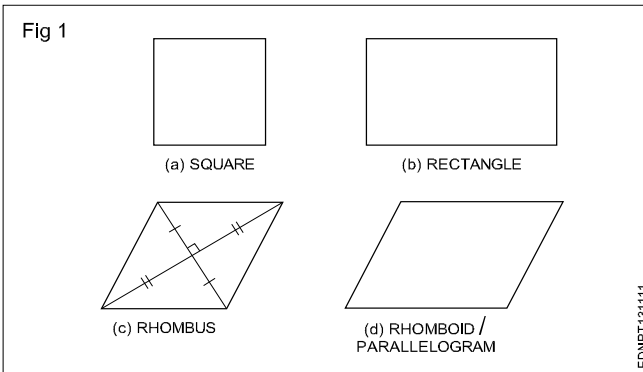

Types of quadrilaterals (Fig 1)

- Square
- Rectangle
- Rhomboid / Parallelogram

Square: In a square all the four sides are equal and its four angles are at right angles. The two diagonals are equal and perpendicular to each other.

Rectangle (Fig 2): In a rectangle, opposite sides are equal and parallel and all four angles are right angles.

Fig 2 shows a rectangle ABCD, Sides AB = DC and BC = AD. Diagonals AC and BD are equal. Diagonals are not bisected at right angles.

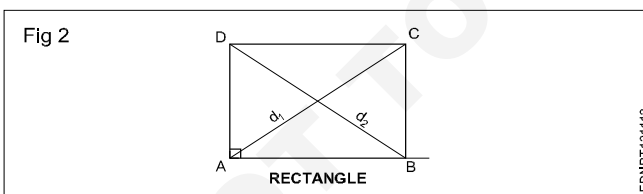

Rhomboid/Parallelogram (Fig 3): In a parallelogram, opposite sides are equal and parallel. Opposite angles are also equal. Diagonals are not equal but bisect each other.

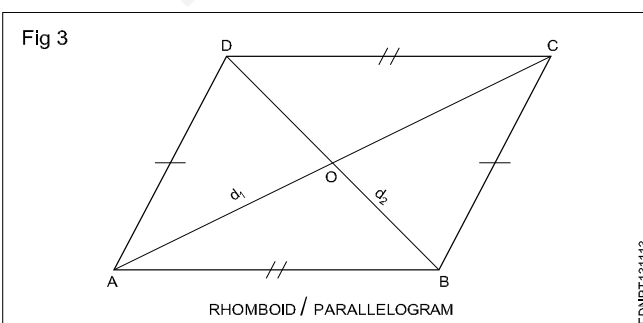

Procedure to draw the square, rectangle and parallelogram

Square

1 **1st method** (Fig 1): A square of side 50 mm by erecting perpendicular using compass and 45° set square.

Draw a line 50mm. 'A' as centre draw an arc of convenient radius. Same arc cut and mark as PQR. Draw a line perpendicular, mark 50mm and make a square as shown in figure.

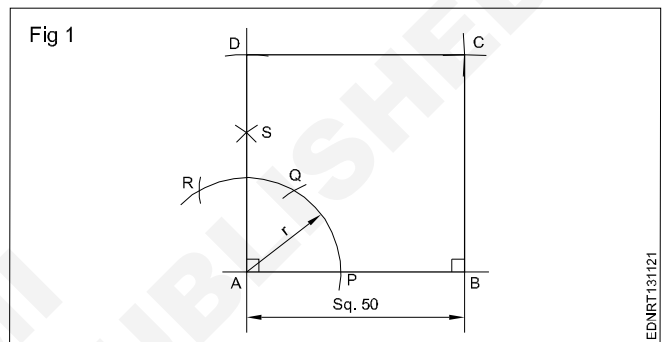

2 **2nd method** (Fig 2): A square of side 60 mm using 45° setsquare and compass.

Draw a horizontal line AB = 60 mm. From point 'A' & 'B' using 45° setsquare draw diagonal and circle of radius OA with centre 'O'. Join points AD, DC & CB to complete the required square.

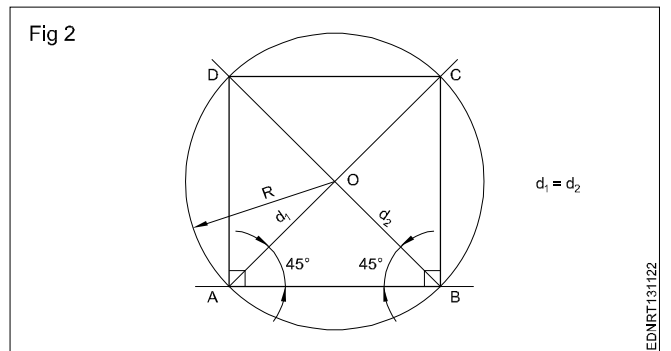

3 **3rd method** (Fig 3): A square of side 60 mm long by erecting perpendicular and also using 45° setsquare. Mark AD, BC and join ABCD to get the required square.

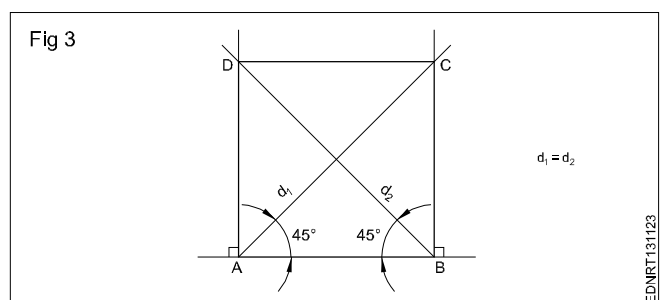

4 Square having diagonal 60 mm (Fig 4)

Draw horizontal and vertical centre lines intersect at 'O' and make a circle. Join all the points ABC&D to get the required square.

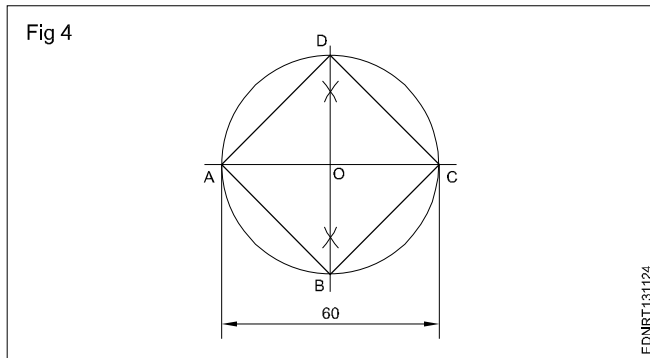

5 Rectangle (Fig 5)

Draw AB = 75 mm and side AD = 45 mm using setsquare and compass. Draw BC = 45 mm using setsquare and compass. Join ABCD to get the required rectangle.

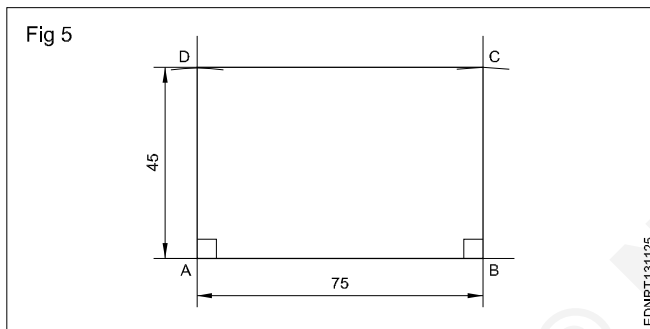

6 Rectangle - Diagonal - 60 mm and one side 20 mm 1st method (Fig 6a)

2nd method (Fig 6b)

ADBC is the required rectangle of side 20 mm and diagonal 60 mm by using setsquare and compass.

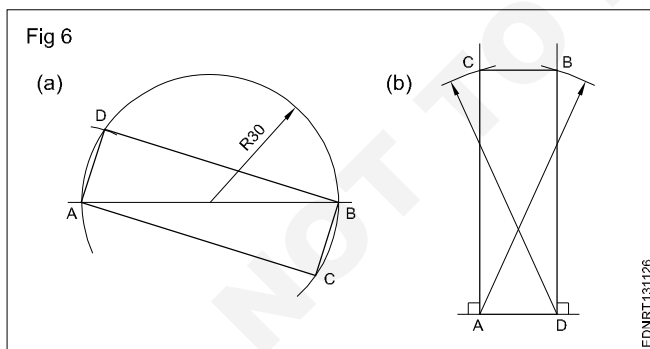

7 Parallelogram (Fig 7)

Sides = 75 mm and 40 mm, angle 50°

- Draw line AD equal to 40 mm and 50° angle to AB.
- 'D' as centre, draw an arc of radius equal to AB.
- 'B' as centre, draw an arc of radius equal to AD, upwards such that they meet at a point 'C'. Join ABCD to get the required parallelogram.

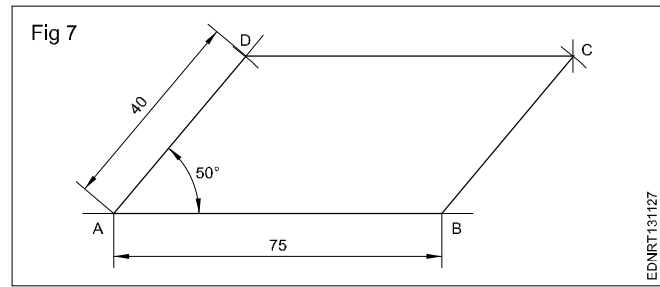

8 Parallelogram (Fig 8)

Parallelogram - Side AB = 60 mm

Diagonal AC = 90 mm $\angle ABC = 120^\circ$

- Draw a line AB = 60 mm. Draw a line from B to an angle 120° to AB.
- 'A' as centre with radius 90 mm, draw an arc cutting 120° line from 'B' at 'C'.
- 'C' as centre, radius = AB, draw an arc.
- 'A' as centre and BC as radius, draw another arc, both arcs meet at 'D'. Join AD and DC.

ABCD is the required parallelogram.

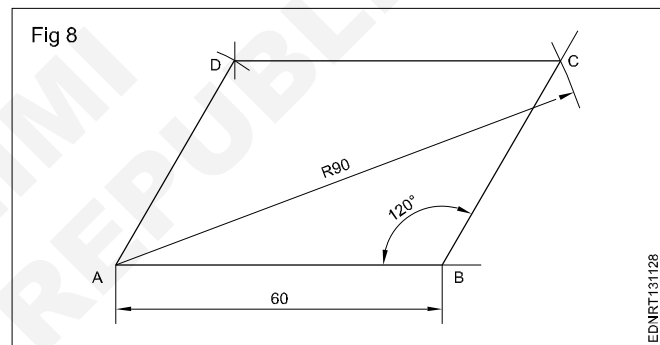

9 Parallelogram (Fig 9)

Sides AB = 55 mm, BC = 40 mm and vertical height = 30 mm.

- Draw the line AB = 55 mm long.
- 'A' and 'B' as centres and radius (R) 30 mm, draw arcs above the line.
- Draw a parallel tangential line to AB touching the arcs.
- 'A' and 'B' as centres, draw an arc of 40 mm radius cutting the line at 'D' and 'C'.

ABCD is the required parallelogram.

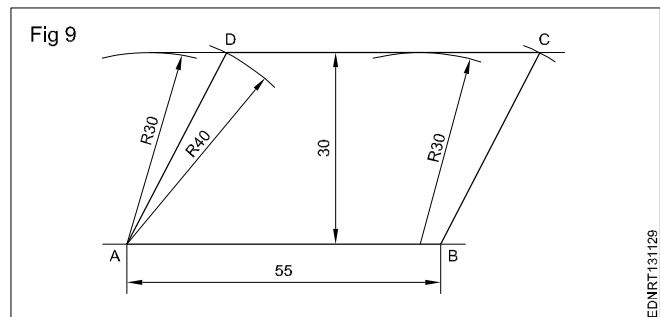

Lettering and numbering - Single stroke

Styles of lettering: Many styles of lettering are in use today. However, a few styles which are commonly used are shown in Fig 1.

Fig 1

ABCDEFGH abcdefgh	GOTHIC ALL LETTERS HAVING THE ELEMENTARY STROKES OF EVEN WIDTH ARE CLASSIFIED AS GOTHIC
ABCDEFGH abcdefgh	ROMAN ALL LETTERS HAVING THE ELEMENTARY STROKES "ACCENTED" OR CONSISTING OF HEAVY AND LIGHT LINES ARE CLASSIFIED AS ROMAN
<i>ABCDEFGH</i> <i>abcdefgh</i>	ITALIC ALL SLANTING LETTERS ARE CLASSIFIED AS ITALIC. THESE MAY BE FURTHER DESIGNATED AS ROMAN-ITALICS, GOTHIC-ITALICS, TEXT-ITALICS
ABCDEF abcde	TEXT THIS TERM INCLUDES ALL STYLES OF OLD ENGLISH, GERMAN TEXT, BRADELY TEXT OF OTHERS OF VARIOUS TRADE NAMES. TEXT STYLES ARE TOO ILLEGIBLE FOR COMMERCIAL PURPOSES

EDNRT131211

Standard heights/Width: The standard heights recommended by BIS SP: 46-2003 are in the progressive ratio of "square root 2". They are namely 2.5 - 3.5 - 5 - 7 - 10 - 14 and 20 mm. The height of lower case letter (without tail or stem) are 2.5, 3.5, 5, 7, 10 and 14 mm.

There are two standard ratios for the line thickness "d". They are A & B. In A = line thickness (d) is h/14 and in B=line thickness (d) is h/10.

Lowercase means small letters, as opposed to capital letters. The word yes, is for example, is in **lowercase**, while the word YES is in **upper case**. For many programmes, this distinction is very important. Programmes that distinguish between **uppercase** and **lowercase** are said to be case sensitive

The width of different letters in terms of "d" is as follows:

Lettering A

Width (W)	Capital letters	Width
1	I	1d
5	J,L	5d
6	C,E,F	6d
7	B,D,G,H,K,N,O,P,R,S,T,U & Z	7d
8	A,Q,V,X,Y	8d
9	M	9d
12	W	12d

Lower case letters and numerals

Width (W)	Letters/Numerals	Width
1	i	1d
3	j,l	3d
4	f,t,l	4d
5	c,r	5d
6	a,b,d,e,g,h,k,n,o,p,q,s,u,v;3;5	6d
7	a,0 (zero), 2,4,6,7,0,8,9	7d
9	m	9d
10	w	10d

The width of different letters in terms of stroke (line) is as follows:

Uppercase Lettering BIS SP: 46-2003

Width (W)	Capital letters
1	I
4	J
5	C,E,F,L
6	B,D,G,H,K,N,O,P,R,S,T,U & Z
7	A,M,Q,V,X,Y
9	W

Lower case letters and numerals

Width (W)	Letters/Numerals
1	i
2	l
3	j,l
4	c,f,r,t
5	a,b,d,e,g,h,k,n,o,q,s,u,v,x,y,x 0,2,3,5 to 9
6	0,2,3,5 to 9 a,4

Spacing of letters: Recommended spacing between characters, a minimum spacing of baselines and minimum spacing between words as per BIS SP: 46-2003 are given below in Fig 2.

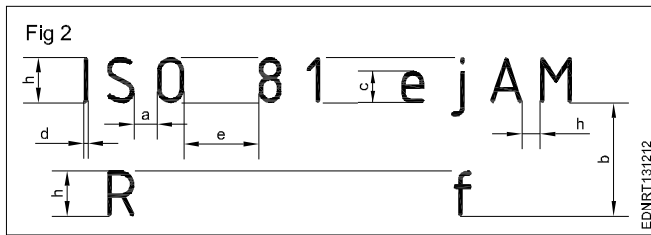

Lettering

Procedure

- 1 Print 10 mm single stroke capital letters and numerals in vertical style using either scale or set-square and by freehand. (Fig 1)

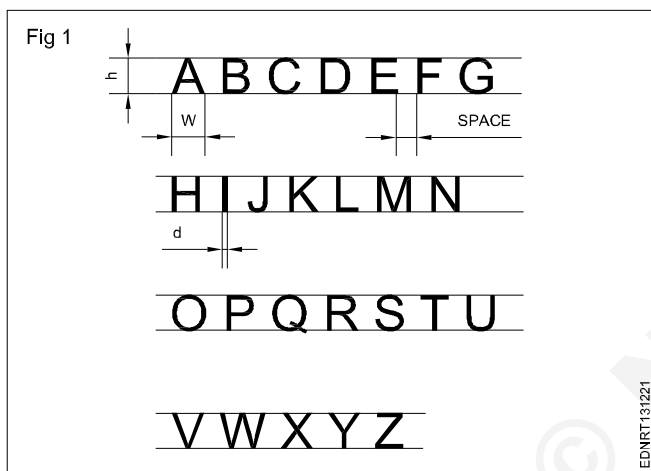

- Draw horizontal parallel lines (thin lines) of 10 mm distance.

10 mm distances denote the height of the letter.

- Mark the width of the letters recommended by BIS (IS:9609-1983)

The width of different letters in terms of 'd' is as follows: 'd' indicates stroke thickness i.e d: h/ 10.

Width (W)	Capital letters
1	I
4	J
5	C, E, F, L
6	B, D, G, H, K, N, O, P, R, S, T, U & Z
7	A, M, Q, V, X, Y
9	W

For curved letters use a smooth freehand curve.
Print straight line letters using either scale or set-squares.
To maintain the uniform thickness of the line, use a conical point soft grade pencil and avoid too much sharpness.
Guidelines of both top and bottom should always be drawn with a sharp pencil.

Numerals 2.1 (Fig 2)

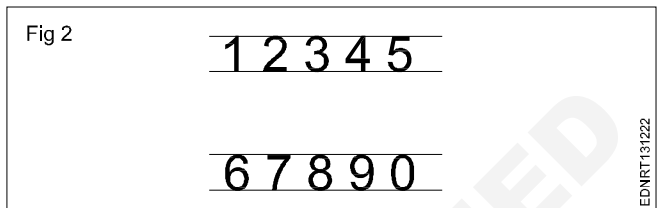

- Follow the same procedure of letters.
- 'h' is height of numerals and 'd' is the stroke thickness.
- Width of numerals in terms of 'd' is as follows shown in square grid (Fig 3).

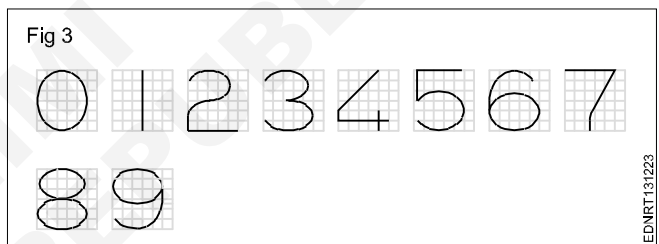

- 2 Print 10 mm single stroke capital letters and numerals in inclined style (Fig 4).

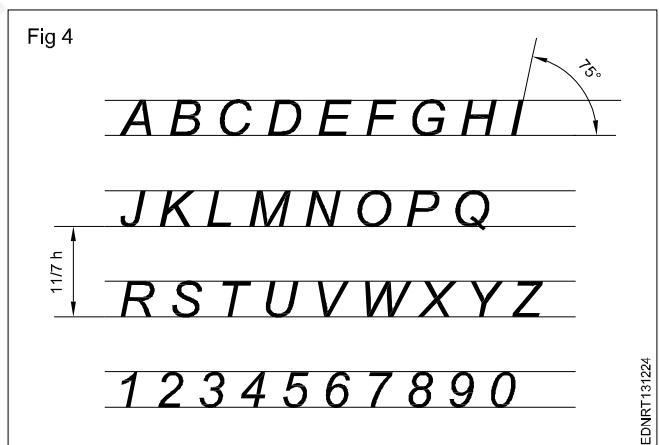

Practice the following lettering exercises in A3/A4 paper as per the given ratio

1 Single stroke inclined letters of ratio 7:6, 7:5, 7:4, 7:3, 7:1 (Fig 5)

Fig 5



SINGLE STROKE INCLINED LETTERS

EDNRT131225

2 Single stroke vertical letters of ratio 7:6, 7:5, 7.4, 7:3, 7:1 (Fig 6)

Fig 6

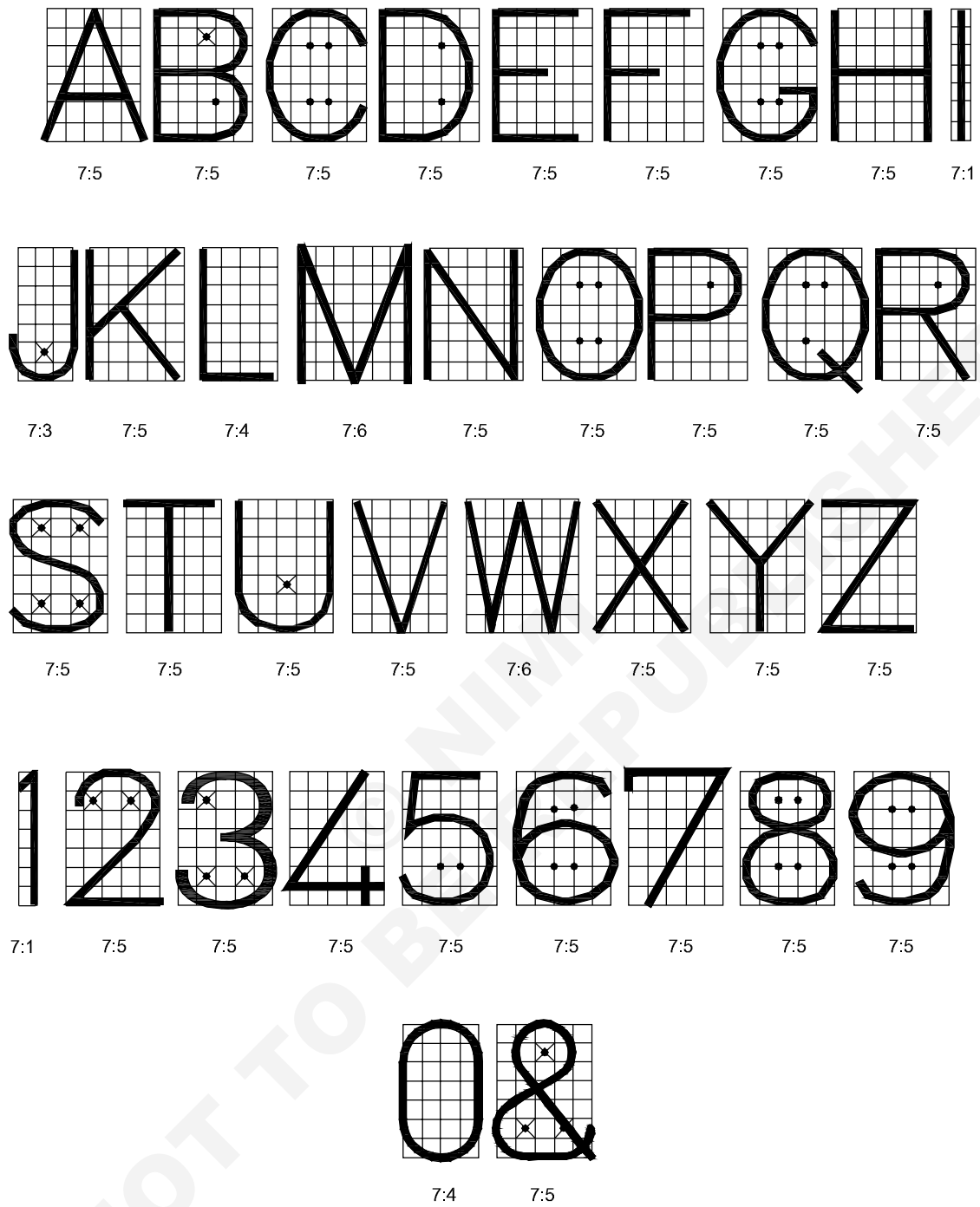

SINGLE STROKE VERTICAL LETTERS

EDNRT131226

Reading of dimension and dimensioning practice - Dimensioning

Dimensioning - Types of arrow heads and leader line with text

Dimension line: These are thin continuous lines, terminated at ends by arrowheads, dots or oblique lines touching the extension line. (Fig 1)

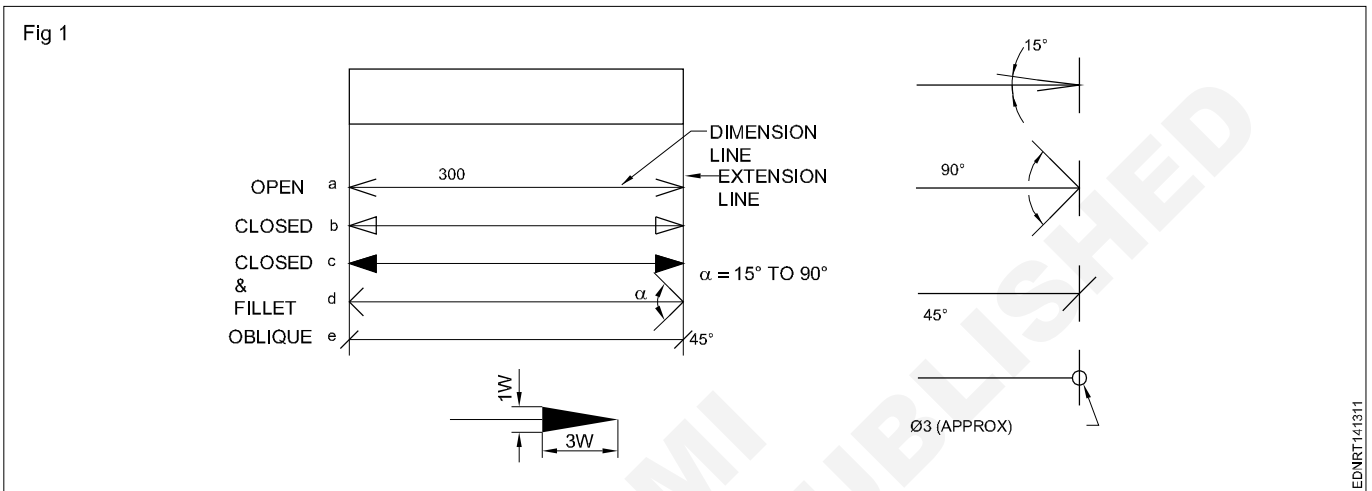

A dimension line may cut or cross another dimension line where there is no other way.

Dimension to the hidden lines be avoided. (Fig 2)

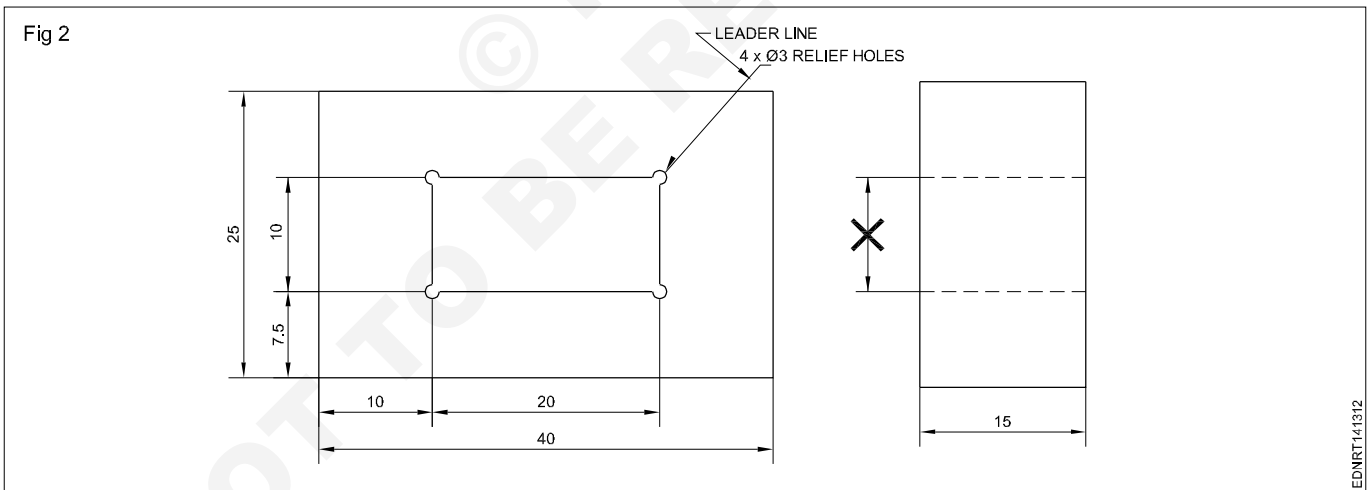

Arrowheads may be placed outside where space is insufficient.

Leader line: It is a thin continuous line. It connects a note or dimension with the features to which it applies. (Fig 2)

Termination and Origin indication: The size of the terminations (arrowheads/oblique strokes) shall be proportional to the size of the drawing. Only one style of arrowhead shall be used on a single drawing. However, where the space is too small for the arrowheads, it may be substituted by a dot or by an oblique line. Arrowheads are drawn as short lines forming barbs at any convenient

included angle between 15° and 90°. They may be open, closed or closed and filled in. Oblique strokes are drawn as short lines inclined at 45°. (Fig 1)

Indicating dimensional values on drawings: All dimensional values shall be shown on drawings in characters of sufficient size to ensure complete legibility on the original drawings as well as on reproductions made from micro-filming.

They shall be placed in such a way that they are not crossed or separated by any other line on the drawing.

Dimensioning - Position of dimensioning (aligned, unidirectional)

Definitions related to dimensioning

Dimension: It is a numerical value expressed as an appropriate unit of measurement and indicated graphically on technical drawings with lines, symbols and notes.

Dimensions are classified according to the following types:

Functional dimension (F): It is a dimension that is essential to the function of the component or space. They are generally shown with limits. (Fig 1)

Non-functional dimension (NF): It is a dimension that is not essential for the function of the component or space.

Auxiliary or Reference dimension (AUX/REF): It is the dimension given for information only. It is derived from the values given on the drawing or related documents and it will not be given for production or inspection. (Fig 1)

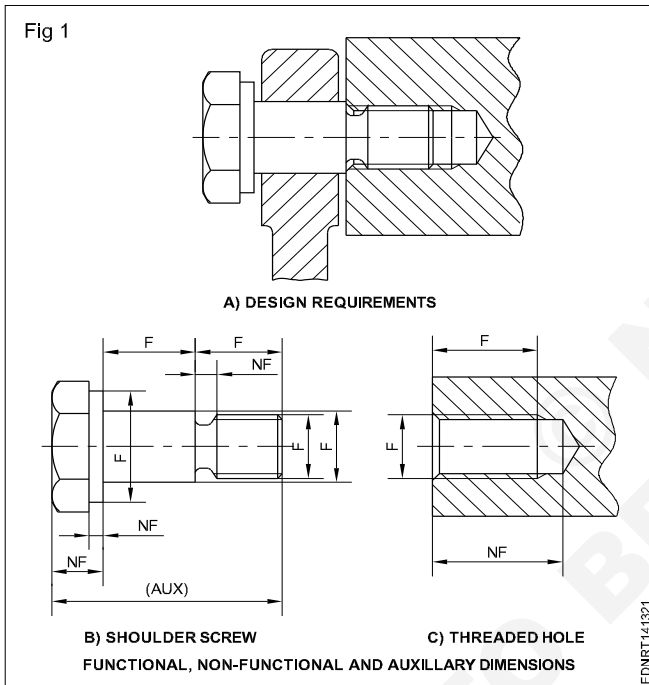

Methods of indicating values

Methods of indicating values: There are two methods used for indicating the values. Only one method should be used on any drawing.

Method 1 Aligned system

Dimensional values shall be placed parallel to their dimension lines and preferably near the middle, above and clear of the dimension line. However, values shall be indicated so that they can be read from the bottom of the drawing. Dimension lines should not be broken. Dimensioning of angles is also given in the same way. (Fig 1) This method is known as an **aligned system** of dimensioning.

Method 2 Unidirectional system

Dimensional values shall be indicated so that they can be read from the bottom of the drawing sheet. Non-horizontal

dimension lines are interrupted, preferably near the middle so that the value can be inserted. (Fig 2). This method is termed a **unidirectional system** of dimensioning.

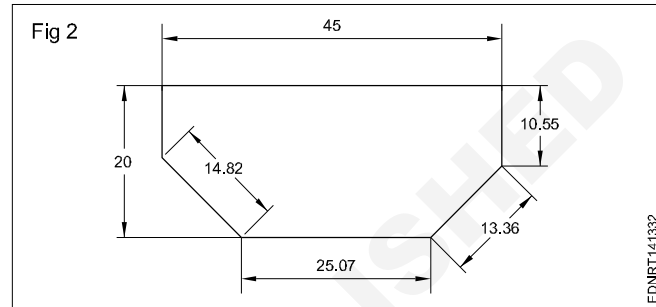
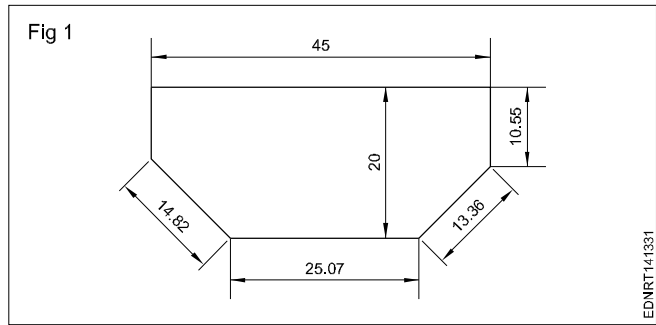

Chain dimensioning: It is used where the possible accumulation of tolerances does not infringe (effect) on the functional requirement of the component. (Fig 3)

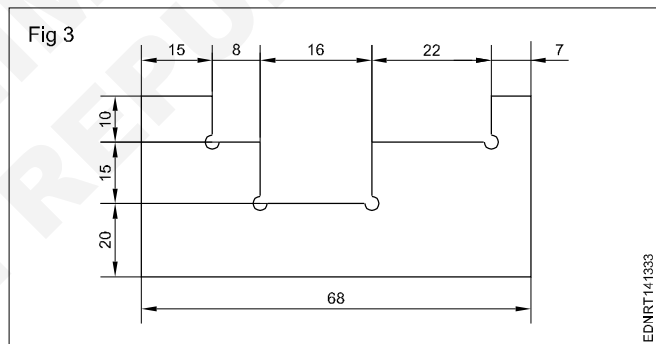

Dimensioning from a common feature is used where several dimensions of the same direction relate to a common origin.

Dimensioning from a common feature may be executed as parallel dimensioning or as superimposed running dimensioning.

Combined dimensioning: Dimensions are given in chain dimensioning and parallel dimensioning. The common feature is combined. (Fig 4)

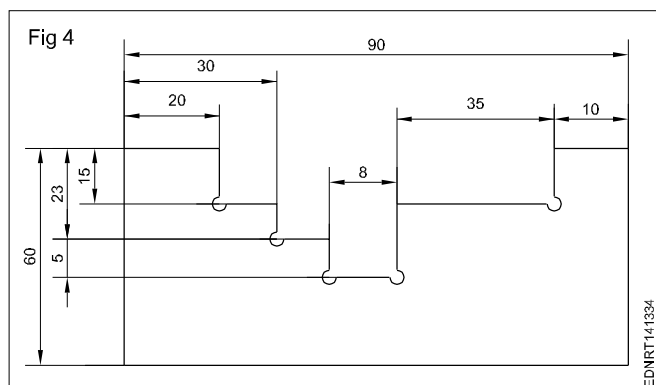

Practice of dimensioning

1 To the given drawing of the profile sheet metal as shown in Fig 1, place the dimensions in the aligned system. (Fig 1a)

- Draw the drawing of the sheet metal to 1:1 scale.
- Draw the extension lines in continuation of outlines.
- Draw the dimension lines. (Fig 1b)
- Place the dimension value near the middle and above the dimension line to be read from "bottom and right hand side" of the drawing.

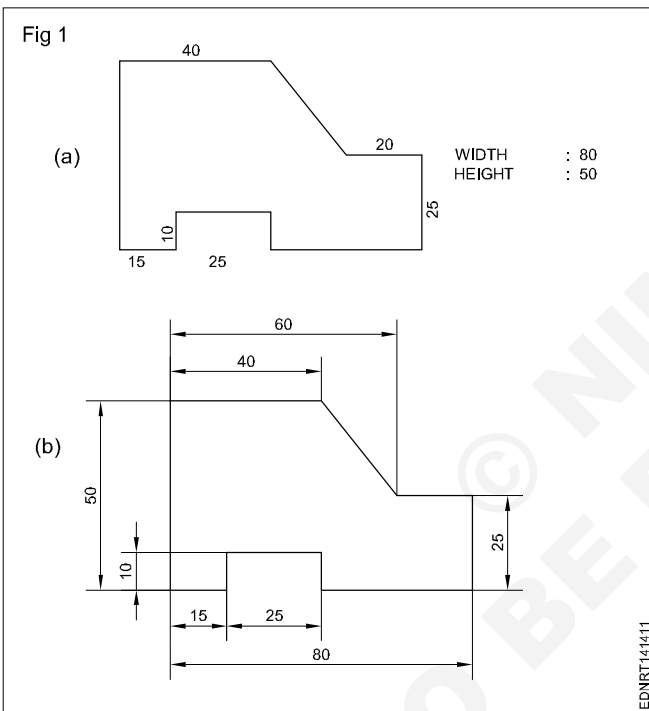

2 To the given drawing of the profile sheet metal as shown in Fig 2a, give the dimensions in the unidirectional system. (Fig 2b)

- Place the horizontal dimensions above and middle of the dimension line without break.
- Break the dimension in the middle of all non-horizontal dimension lines.

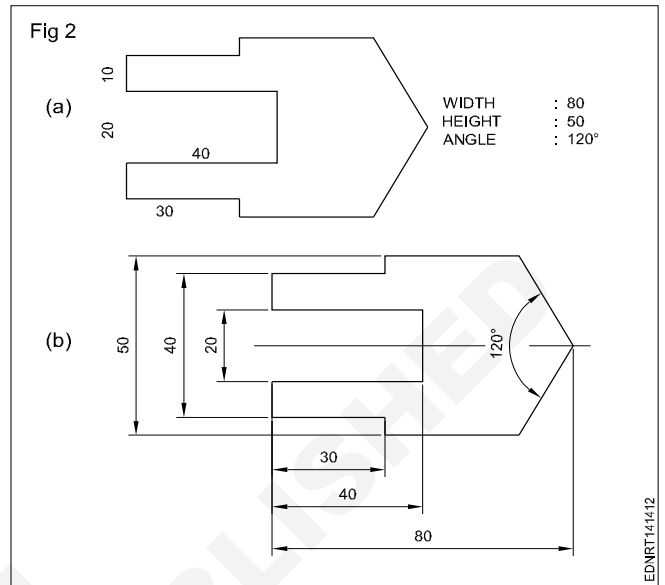

3 Draw the two sheet metal templates to full scale with appropriate lines use 0.5 range line thickness. (Fig 3)

- Draw a rectangular block of length 80 mm and width 50 mm in thin lines.
- Incorporate the features of the template as per the given dimension.
- Draw by thick lines all visible outlines.
- Give dimensions and maintain the line thickness as per the line range (0.5).
- Complete the figure and remove the unwanted lines.

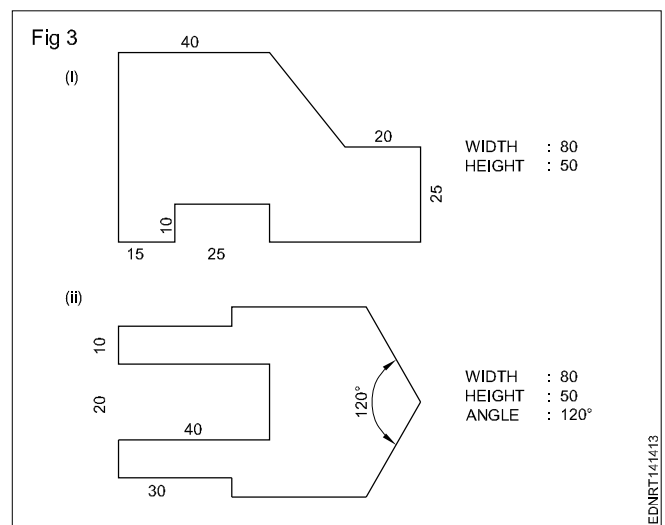

4 Draw the figures given. Maintain the types of lines as per the B.I.S and choose correct line thickness. (Fig 4)

- According to the given dimensions, draw the figures given in Fig 4.
- Select the appropriate lines and maintain uniformity.
- Remove (erase) unwanted lines, arcs and complete the drawing.

Note: Draw the dimension line terminations as per IS:11669-1986.

5 The motor cycle engine gasket is shown in figure 5. There are some mistakes in dimensioning. Reproduce the same in the A3/A4 sheet provided and correct the mistakes according to the aligned system of dimensioning. (Fig 5)

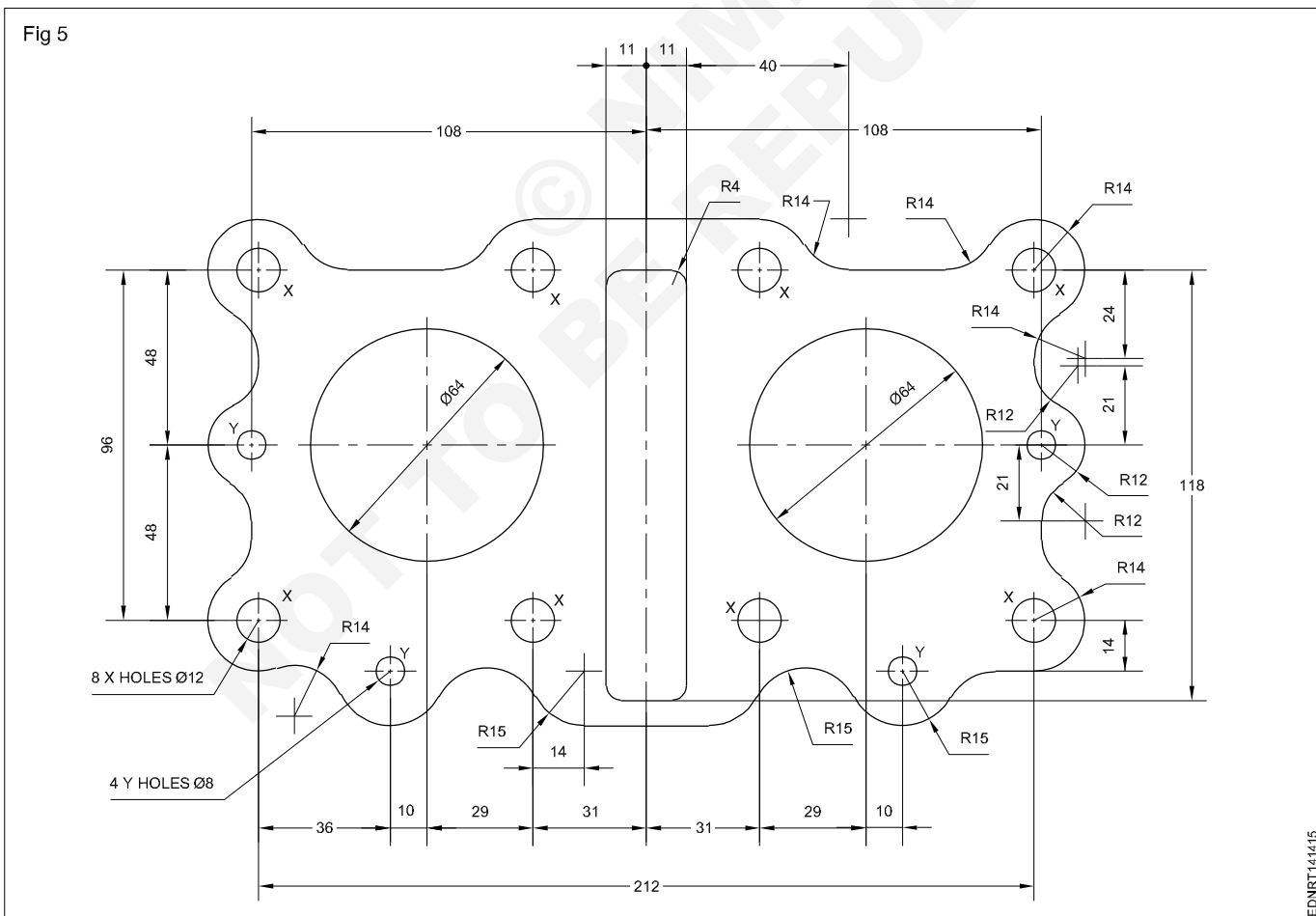
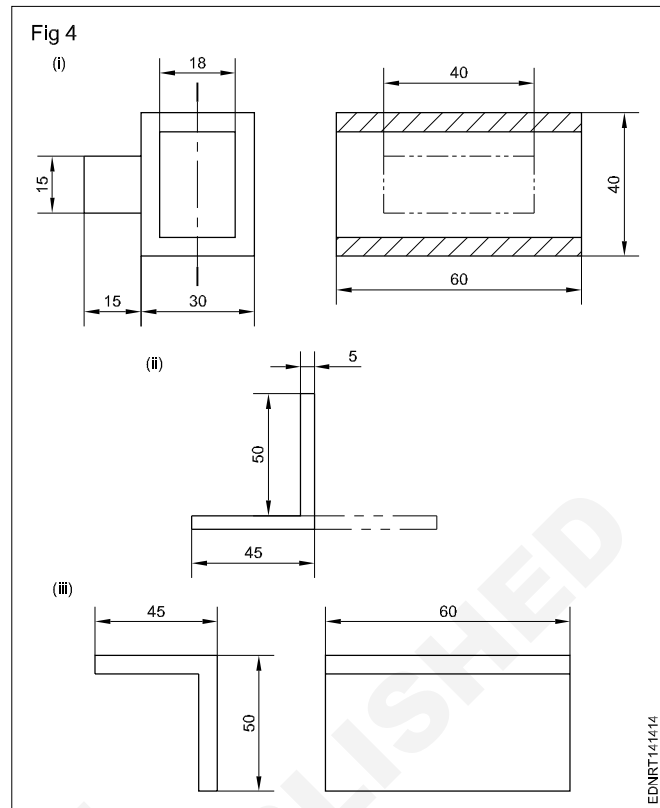

6 Draw the given cover plate and give the dimensions in the aligned system. (Fig 6)

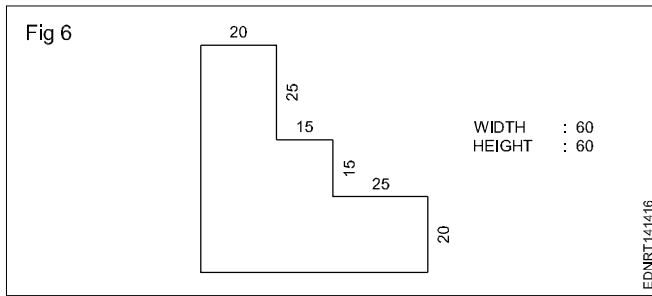



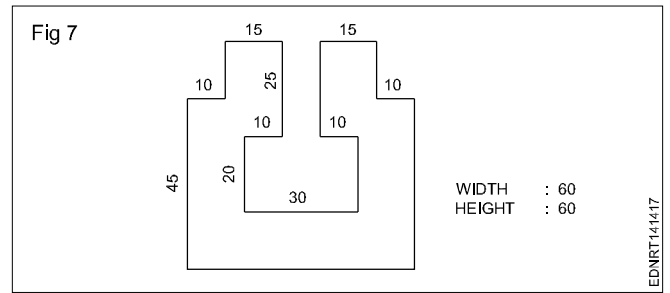





7 Draw the cover plate given in the figure and place the dimensions in the unidirectional system. (Fig 7)



© NIMI
NOT TO BE REPUBLISHED

Symbolic representation - Different symbols used in the rubber technician trade

Sl.No.	Description	Symbol
1	Made with Latex	
2	Not made with natural rubber latex	
3	Tires	
4	Automotive components	
5	Clothing	
6	Flooring	
7	Natural rubber gaskets	
8	Rubber Nozzles	

Sl.No.	Description	Symbol
9	Erasers	
10	Rubber sheet products	
11	Ducting	
12	Rubber adhesives & coating	
13	Rubber gloves	
14	Anti-vibration isolation pads	
15	Rubber swimming tubes	

Reading of job/ process drawing related to rubber technician trade

Natural Latex Harvested (Fig 1)

Rubber tree plantations have far less of a negative impact on the land than other crops, and they encourage much more biological diversity than other monoculture crops. It takes about ten years of growth before the rubber tree starts producing sufficient amounts of latex. This waiting period ensures that new rubber trees are being planted continuously.

Latex is a milky fluid found in the bark of rubber trees. Continuous tubes of latex known as "latex vessels" grow in a spiral around the bark of the rubber tree. When harvesting, the bark is very carefully stripped away to expose the latex vessels. The latex then runs down the side of the tree into some sort of a container (often a coconut shell).



Read and write the following. (Fig 1)

- 1 Write the state latex harvesting in India.
- 2 How long each panel of bank will yield latex?
- 3 How long each rubber tree will be harvest?

Tapping and coagulation (Fig 2)



Latex dripping into a cup from a tapped rubber tree (Fig 2)

When the bark of the Hevea tree is partially cut through (tapped), a milky liquid exudes from the wound and dries to yield a rubbery film. The biological function of this latex is still obscure: it may help wound-healing by protecting the inner bark, or it may serve other biochemical functions. The latex consists of an aqueous suspension of small particles, about 0.5 micrometre in diameter, of cis-polyisoprene, a linear rubbery polymer of high molecular weight. The rubber content of the suspension is about 30 percent.

Read and write the following. (Fig 2)

- 1 How much Latex can yield once?
- 2 When production will start after harvesting?

Latex being extracted from a rubber tree (Fig 3)

Rubber trees are tapped about once every two days, yielding a cupful of latex, containing approximately 50 grams (1.7 ounces) of solid rubber, each time. The standard method of tapping is to score the tree with a knife for half the circumference of the trunk, slanting the cut down from left to right at an angle of 30° starting at the highest point convenient to the tapper. Each subsequent cut is made immediately below its predecessor. Trees are often rested for a period after heavy tapping. Production commences when a tree is 5 or 6 years old; with care, the tree's useful life may extend to more than 20 years. With trees cultivated at a density of 375 per hectare (150 per acre), approximately 2,500 kg of rubber can be produced per hectare per year (that is, approximately one ton per acre per year).



Read and write the following. (Fig 4)

- 1 How much latex can yield once?
- 2 When production will start after harvesting?

Sheets of natural rubber coagulated from latex being passed between rollers (Fig 4)

After collection of the tapped latex, rubber is recovered from emulsion by coagulation with formic acid, creating crumbs that resemble curds of milk. The crumbs are washed, dried between rolls, and compacted into blocks 67 by 33 by 18 cm in size and weighing 33.3 kg. The blocks are then wrapped in polyethylene sheets and packed into one-ton crates for shipping.



Read and write the following. (Fig 4)

- 1 What is the use of formic acid?
- 2 What is the meaning of crumbs?

Sheets of natural rubber hanging from racks in a smoke room for final drying (Fig 5)

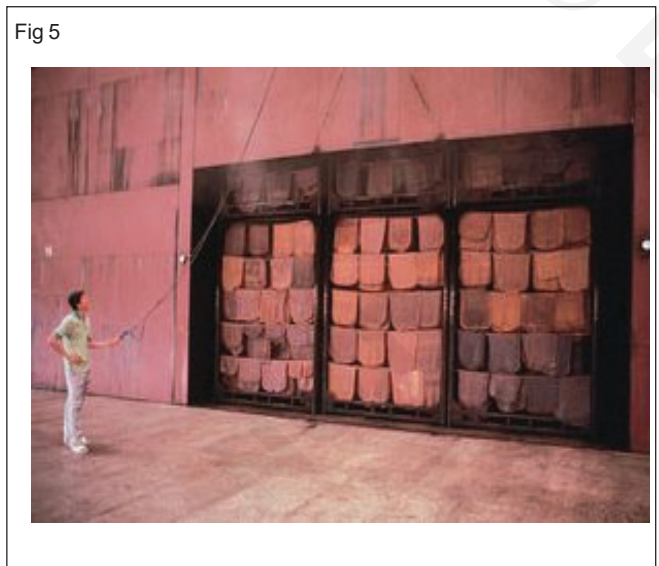

Smoked sheets of natural rubber being inspected and trimmed before being packed into bales (Fig 6)

Other production is as smoked sheet, where the coagulum is pressed into thin sheets that are washed and then dried over a smoky wood fire. The smoke contains natural fungicides that protect against mold growth and impart a characteristic amber colour.



Schematic diagram of the emulsion-polymerization method (Fig 7)

About 10 percent of all natural rubber is shipped as latex, concentrated to a rubber content of approximately 60 percent and used for making dipped goods such as surgical gloves, prophylactics, and toys.

Monomer molecules and free-radical initiators are added to a water-based emulsion bath along with soaplike materials known as surfactants, or surface-acting agents. The surfactant molecules, composed of a hydrophilic (water-attracting) and hydrophobic (water-repelling) end, form a stabilizing emulsion before polymerization by coating the monomer droplets. Other surfactant molecules clump together into smaller aggregates called micelles, which also absorb monomer molecules. Polymerization occurs when initiators migrate into the micelles, inducing the monomer molecules to form large molecules that make up the latex particle.

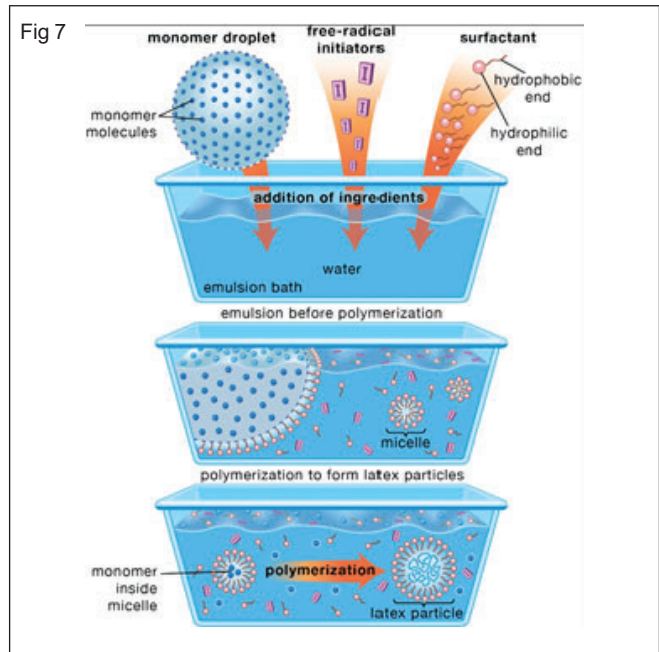

Disc centrifuge working principle (Fig 8)

FIVEMEN Disc centrifuge is a centrifugal separator which can separate solid matter from two kinds of different density liquids on a continuous basis and also to separate two liquids simultaneously. By reducing process cycle

time and labor requirements, these separators offer high cost efficiency in liquid clarification and reclamation, solid-liquid separation and its classification, recovery and thickening of solids and in other such processes.

Fig 8



Multi-Functional Latex Natural Rubber Centrifuge Machine (Fig 9)

Latex series disc separator is good equipment for producing latex. It is mainly used for natural rubber slurry concentration and clarification, makes rubber slurry separate concentrated latex and clear skim latex, and eliminates the solid impurity of whey liquid. Separator's design, manufacture and checking and acceptance comply with national standard GB10897 and GB10898.

Centrifuged latex (Fig 10)

It is mainly used for producing mattress, condoms, gloves and all type of rubber products. The machinery used for centrifuged latex is Alfa level centrifuges manufactured in Sweden. Creamed latex (52% DRC) The Company produces creamed latex, which is mainly used by companies manufacturing mattress, rubberized coir, balloon and adhesives.

Fig 9



Fig 10

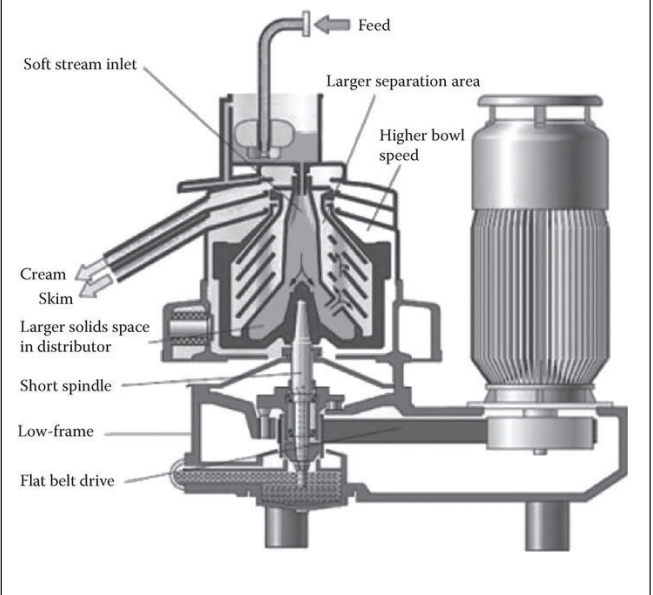

Latex sampling procedures

- Rubber latex may tend to cream on standing.
- The latex shall be thoroughly agitated to obtain a homogenous blend suitable for the withdrawal of a representative sample.
- In all cases, where are drawn from several containers, for exampe 10% sampling of latex in drums or in the case of tanks are made at various depths such samples shall be bulked and stirred.
- The final average sample shall then be bulked and stirred.

Flow chart of latex texting conducted during the production of latex concentrate

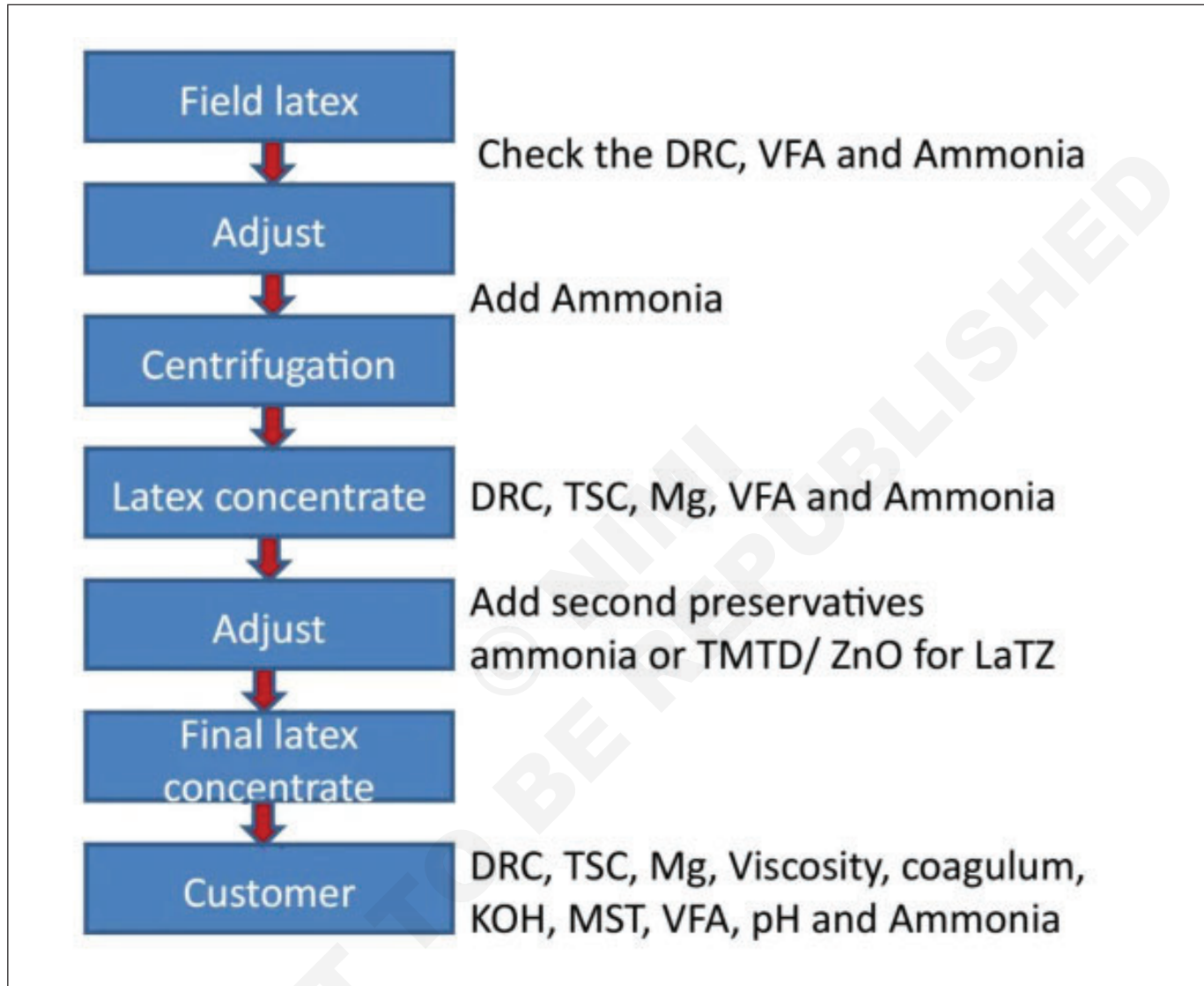

Read and write the following.

- 1 Why water to be added with latex?
- 2 What is the purpose of adding ammonia with latex?
- 3 Why potassium hydraulics to be added?

Procedure for metrolac latexometer method

- 1 Take two pints of water and add it to one pint of well stirred field latex in a gallon measure.
- 2 Mix thoroughly.
- 3 The diluted latex then poured into an aluminum jar in a coagulating pan until the latex overflows.
- 4 Remove any foams on the surface of the latex and allow the metrolac to sink into diluted latex slowly.
- 5 Allow the metrolac to rest without touching the base on the sides of the jar.
- 6 Take the reading on the stem at the base of the meniscus of the latex.
- 7 Verifying the reading by pushing the metrolac down lightly and note the reading.

Rubber testing methods and their evaluation

When choosing rubber products, it is important to be aware of both physical and chemical properties of the component, therefore it is valuable to know rubber testing methods used in the industry, and their values. The properties determined by these tests are often indicated on the products or their data sheets, although we may not know the meaning of the number and letter combinations.

To help you understand these parameters, in the following we are introducing the most common rubber testing methods and interpretations of their results:

- Shore hardness test
- Abrasion test
- Discoloration Metering
- Vertical Rebound Resilience
- Burst Strength test
- Flex Cracking test
- Ozone resistance
- Cold resistance
- Mooney viscosity measurement
- Oscillating-disc rheometer